

Installation and Service Manual

High Efficiency Wall Hung Condensing Gas Boiler

Main Eco Compact Combi

25 — 30

Dear Customer,

Thank you very much for buying this appliance.

Please read through the manual carefully before using the product, and keep it in a safe place for later reference. In order to ensure continued safe and efficient operation we recommend that the product is serviced regularly. Our service and customer service organisation can assist with this.

We hope you enjoy years of problem-free operation with the product.

Contents

1	Safety	6
1.1	Benchmark	6
1.1.1	Building Regulations and the Benchmark Commissioning Checklist	6
1.1.2	The Benchmark Scheme	6
1.1.3	Installer Notification Guidelines	7
1.2	General safety instructions	8
1.3	Recommendations	8
1.4	Specific safety instructions	9
1.4.1	Handling	9
1.5	Liabilities	10
1.5.1	Manufacturer's liability	10
1.5.2	Installer's liability	10
1.5.3	User's liability	10
2	About this manual	11
2.1	General	11
2.2	Additional documentation	11
2.3	Symbols used	11
2.3.1	Symbols used in the manual	11
2.4	Abbreviations/Glossary	11
3	Technical specifications	12
3.1	Homologations	12
3.1.1	Safety, Performance & Quality	12
3.1.2	Certifications	12
3.1.3	Gas category	12
3.1.4	Standards	12
3.2	Technical data	13
3.2.1	Technical information	13
3.2.2	Technical parameters	15
3.3	Dimensions and connections/clearances	16
3.4	Electrical diagram	17
4	Description of the product	19
4.1	General description	19
4.2	Operating principle	19
4.2.1	Air-gas adjustment	19
4.2.2	Combustion	19
4.2.3	Central heating and domestic hot water production	20
4.2.4	Central heating mode	20
4.2.5	Domestic hot water mode	20
4.2.6	Frost protection mode	21
4.2.7	Pump protection	21
4.3	Main components	22
4.3.1	List of components	22
4.4	Control panel description	23
4.4.1	Description of the control panel	23
4.5	Standard delivery	23
4.5.1	Contents of the carton	23
4.6	Accessories and options	24
4.6.1	Optional accessories	24
5	Before installation	25
5.1	Installation regulations	25
5.2	Installation requirements	25
5.2.1	Gas supply	25
5.2.2	Electrical supply	25
5.2.3	Hard water area	26
5.2.4	Bypass	26
5.2.5	System control	26
5.2.6	Treatment of water circulating systems	26
5.2.7	Showers	27
5.2.8	Expansion vessel (CH only)	27
5.2.9	Safety pressure relief valve	27

5.3	Choice of the location	28
5.3.1	Location of the boiler	28
5.3.2	Bath and shower rooms	29
5.3.3	Ventilation	29
5.3.4	Condensate drain	30
5.3.5	Clearances	32
5.3.6	Flue/chimney location	32
5.3.7	Horizontal flue/chimney systems	34
5.3.8	Flue/chimney trim	35
5.3.9	Terminal guard	35
5.3.10	Flue/chimney deflector	35
5.3.11	Flue/chimney accessories	35
5.4	Transport	35
5.5	Unpacking & initial preparation	36
5.5.1	Unpacking	36
5.5.2	Initial preparation	36
5.6	Connecting diagrams	37
5.6.1	Filling information	37
5.6.2	Domestic hot water circuit	37
6	Installation	39
6.1	General	39
6.2	Assembly	39
6.2.1	Fitting the pressure relief discharge pipe	39
6.2.2	Connecting the condensate drain	40
6.3	Air supply/flue gas connections	40
6.3.1	Connecting the flue/chimney	40
6.4	Electrical connections	42
6.4.1	Making the electrical connection	42
6.4.2	Connecting outdoor sensor	44
6.4.3	Identifying label	45
6.4.4	Outdoor sensor graph	45
6.4.5	Setting outdoor sensor curve	45
6.5	Filling the installation	46
6.5.1	Flushing the system	46
6.5.2	Fill the installation	46
6.5.3	Filling the condensate trap	46
7	Commissioning	47
7.1	General	47
7.2	Checklist before commissioning	47
7.2.1	Preliminary electrical checks	47
7.2.2	Checks	47
7.3	Commissioning procedure	48
7.3.1	De-Aeration function	48
7.4	Gas settings	48
7.4.1	Check the operational (working gas inlet pressure and gas rate)	48
7.4.2	Checking combustion - chimney sweep mode	49
7.5	Configuring the system	52
7.5.1	System draining	52
7.6	Final instructions	52
7.6.1	Handover	52
8	Operation	53
8.1	Use of the control panel	53
8.1.1	Control panel	53
8.2	Start up	53
8.3	Frost protection	53
9	Maintenance	54
9.1	General	54
9.2	Standard inspection and maintenance operations	55
9.2.1	Annual Servicing	55
9.2.2	Checking the water pressure	56
9.2.3	Checking the expansion vessel	56
9.2.4	Checking the automatic air vent	56

9.2.5	Checking the burner and cleaning the heat exchanger	56
9.3	Specific maintenance instructions	57
9.3.1	Detection/spark ignition electrode	57
9.3.2	NTC flue sensor	57
9.3.3	Flow and return sensors	58
9.3.4	Safety overheat thermostat	58
9.3.5	DHW temperature sensor (NTC)	58
9.3.6	Pressure Gauge	58
9.3.7	Hall effect sensor	59
9.3.8	DHW flow regulator and filter	59
9.3.9	Safety pressure relief valve	59
9.3.10	Diverter valve motor	60
9.3.11	Expansion vessel	60
9.3.12	Gas valve	60
9.3.13	Pump - head only	63
9.3.14	Pump - complete	63
10	Troubleshooting	64
10.1	Error codes	64
10.1.1	Initial error fault finding checks	64
10.1.2	Display of error codes	64
10.2	Fault finding	65
10.2.1	Central heating	65
10.2.2	Domestic hot water	66
10.2.3	Fault finding solutions sections A to E	67
10.2.4	Fault finding solutions sections F to H	68
10.2.5	Fault finding solutions sections I to M	69
11	Decommissioning	70
11.1	Decommissioning procedure	70
12	Disposal	71
12.1	Disposal and recycling	71
13	Spare parts	72
13.1	Short parts list	72
14	Appendix	73
14.1	Benchmark commissioning checklist	73
14.2	Service records	74

1 Safety

1.1 Benchmark

1.1.1 Building Regulations and the Benchmark Commissioning Checklist

Building Regulations (England & Wales) require notification of the installation of a heating appliance to the relevant Local Authority Building Control Department. This can be achieved via a Competent Persons Self Certification Scheme as an option to notifying the Local Authority directly.

The Health & Safety Executive operates the 'Gas Safe Register', a self-certification scheme for gas heating appliances.

This company is a member of the Benchmark initiative and fully supports the aims of the programme. Its aim is to improve the standards of installation and commissioning of central heating systems in the UK and to encourage the regular servicing of all central heating systems to ensure safety and efficiency.

Building Regulations require that installations should comply with manufacturer's instructions. It is therefore important that the commissioning checklist is completed by the installer. The relevant section of Building Regulations only relates to dwellings. Therefore the checklist only applies if the appliance is being installed in a dwelling or some related structure.

The flowchart opposite gives guidance for installers on the process necessary to ensure compliance with Building Regulations.

1.1.2 The Benchmark Scheme

Benchmark places responsibilities on both manufacturers and installers. The purpose is to ensure that customers are provided with the correct equipment for their needs, that it is installed, commissioned and serviced in accordance with the manufacturer's instructions by competent persons and that it meets the requirements of the appropriate Building Regulations. The Benchmark Checklist can be used to demonstrate compliance with Building Regulations and should be provided to the customer for future reference.

Installers are required to carry out installation, commissioning and servicing work in accordance with the Benchmark Code of Practice which is available from the Heating and Hotwater Industry Council who manage and promote the Scheme. Visit www.centralheating.co.uk for more information.

Fig.1 Benchmark



1.1.3 Installer Notification Guidelines

Fig.2 Installer Notification Guidelines

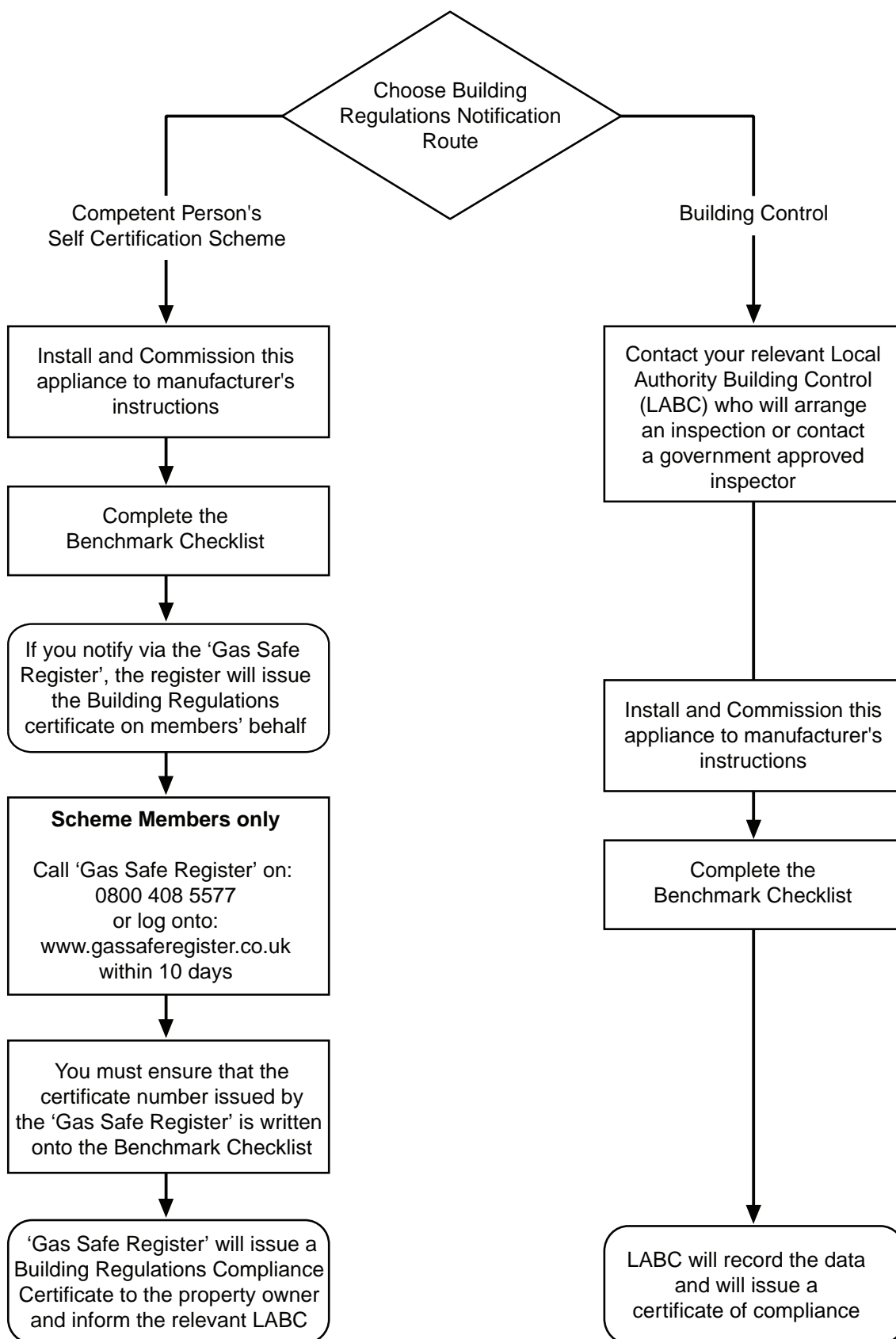

AD-3000696-01

1.2 General safety instructions



Danger

This boiler can be used by children aged 8 years and above and by persons with reduced physical, sensory or mental capabilities or lack of experience and knowledge when they have been given supervision or instruction concerning the safe use of the device and understand the resulting risks. Children must not be allowed to play with the appliance. Cleaning and user maintenance must not be carried out by children without supervision.



Danger

If you smell gas:

1. Do not use a naked flame, do not smoke, do not operate electrical contacts or switches (doorbell, light, motor, lift, etc.).
2. Shut off gas supply.
3. Open the windows.
4. Trace possible leaks and seal them immediately.
5. If the gas leak is before the gas meter, contact the supplier
6. Telephone the National Gas Emergency Service on:- 0800 111 999.



Danger

If you smell flue gases:

1. Switch off the boiler.
2. Open the windows.
3. Trace possible leaks and seal them immediately.



Warning

Do not touch the flue gas pipes. Depending on the boiler settings, the temperature of the flue gas pipes may exceed 60°C.



Warning

Do not touch the radiators for long periods. Depending on the boiler settings, the temperature of the radiators may exceed 60°C.



Warning

Take precautions with the domestic hot water. Depending on the boiler settings, the domestic hot water temperature may exceed 65°C.



Danger

Before any work, switch off the mains supply to the boiler.



Caution

After maintenance or repair work, check the entire heating installation to ensure that there are no leaks.

1.3 Recommendations



Warning

Installation and maintenance of the boiler must be carried out by a qualified installer in accordance with local and national regulations.



Warning

If the mains lead is damaged, it must be replaced by the original manufacturer, the manufacturer's dealer or another suitably skilled person to prevent hazardous situations from arising.



Warning

Always disconnect the mains supply and close the main gas tap when working on the boiler.

**Caution**

Make sure the boiler can be reached at all times. The boiler must be installed in a frost-free area. In the case of a fixed connection to the power cord, you must always install a main double pole switch with an opening gap of at least 3 mm (EN 60335-1). Drain the boiler and central heating system if you are not going to use your home for a long time and there is a chance of frost. The frost protection does not work if the boiler is out of operation. The boiler protection only protects the boiler, not the system. Check the water pressure in the system regularly. If the water pressure is lower than 0.8 bar, the system must be topped up (recommended water pressure between 1 and 2 bar).

Important

Keep this document near to the boiler.

Important

Casing panels may only be removed for maintenance and servicing purposes. Refit all panels when maintenance work and servicing are complete.

**Note**

Instruction and warning labels must never be removed or covered and must be clearly legible throughout the entire service life of the boiler. Replace damaged or illegible instruction and warning labels immediately.

**Note**

The boiler must not be modified in any way.



1.4 Specific safety instructions

1.4.1 Handling

**General**

The following advice should be adhered to, from when first handling the boiler to the final stages of installation, and also during maintenance. Most injuries as a result of inappropriate handling and lifting are to the back, but all other parts of the body are vulnerable, particularly shoulders, arms and hands. Health & Safety is the responsibility of EVERYONE.

There is no "safe" limit for one man - each person has different capabilities. The boiler should be handled and lifted by TWO PEOPLE.

Do not handle or lift unless you feel physically able.

Wear appropriate Personal Protection Equipment e.g. protective gloves, safety footwear etc.

Preparation

Co-ordinate movements - know where, and when, you are both going.

Minimise the number of times needed to move the boiler - plan ahead.

Always ensure when handling or lifting the route is clear and unobstructed. If possible avoid steps, wet or slippery surfaces, unlit areas etc. and take special care on ladders/into lofts.

Technique

When handling or lifting always use safe techniques - keep your back straight, bend your knees. Don't twist - move your feet, avoid bending forwards and sideways and keep the load as close to your body as possible.

Where possible transport the boiler using a sack truck or other suitable trolley.

Always grip the boiler firmly, and before lifting feel where the weight is concentrated to establish the centre of gravity, repositioning yourself as necessary. See the "Installation" section of these instructions for recommended lift points.

Remember

The circumstances of each installation are different. Always assess the risks associated with handling and lifting according to the individual conditions.

If at any time when installing the boiler you feel that you may have injured yourself STOP !! DO NOT "work through" the pain - you may cause further injury.

IF IN ANY DOUBT DO NO HANDLE OR LIFT THE BOILER — OBTAIN ADVICE OR ASSISTANCE BEFORE PROCEEDING !

1.5 Liabilities

1.5.1 Manufacturer's liability

Our products are manufactured in compliance with the requirements of the various Directives applicable. They are therefore delivered with the **CE** marking and any documents necessary. In the interests of the quality of our products, we strive constantly to improve them. We therefore reserve the right to modify the specifications given in this document.

Our liability as manufacturer may not be invoked in the following cases:

- Failure to abide by the instructions on installing the appliance.
- Failure to abide by the instructions on using the appliance.
- Faulty or insufficient maintenance of the appliance.

1.5.2 Installer's liability

The installer is responsible for the installation and initial commissioning of the appliance. The installer must observe the following instructions:

- Read and follow the instructions given in the manuals provided with the appliance.
- Install the appliance in compliance with prevailing legislation and standards.
- Carry out initial commissioning and any checks necessary.
- Explain the installation to the user.
- If maintenance is necessary, warn the user of the obligation to check the appliance and keep it in good working order.
- Give all the instruction manuals to the user.

1.5.3 User's liability

To guarantee optimum operation of the system, you must abide by the following instructions:

- Read and follow the instructions given in the manuals provided with the appliance.
- Call on a qualified professional to carry out installation and initial commissioning.
- Get your installer to explain your installation to you.
- Have the required inspections and maintenance carried out by a qualified installer.
- Keep the instruction manuals in good condition close to the appliance.

2 About this manual

2.1 General

This manual is intended for the installer of a Main Eco Compact Combi boiler.

2.2 Additional documentation

These Installation & Service Instructions must be read in conjunction with the Flue Accessories Fitting Guide supplied in the Literature Pack.

Various timers, external controls, etc. are available as optional extras. Full details are contained in the relevant sales literature.

2.3 Symbols used

2.3.1 Symbols used in the manual

This manual uses various danger levels to draw attention to special instructions. We do this to improve user safety, to prevent problems and to guarantee correct operation of the appliance.



Danger

Risk of dangerous situations that may result in serious personal injury.



Danger of electric shock

Risk of electric shock.



Warning

Risk of dangerous situations that may result in minor personal injury.



Caution

Risk of material damage.

Important

Please note: important information.



See

Reference to other manuals or pages in this manual.

2.4 Abbreviations/Glossary



BS	British Standard
CH	Central heating
DHW	Domestic hot water
GB	Great Britain
HHIC	Heating and Hotwater Industry Council
Hi	Lower heating value (LHV)
Hs	Higher heating value (HHV)
IE	Ireland
PCU	PCB for managing burner operation
Pn	Nominal output
Pnc	Condensing output
SU	Safety PCB

3 Technical specifications

3.1 Homologations

3.1.1 Safety, Performance & Quality

This boiler has been assessed by an appropriate Notified Body and shown to meet the requirements of all Directives and Regulations as applicable. These Directives and Regulations lay down requirements for the safety and efficiency of the appliance, together with its design, construction and use of materials. They also require the production process to be covered by an approved and monitored system of quality assurance.

3.1.2 Certifications

Tab.1 Certifications

CE certificate number	
NOx class	6
Boiler type	C ₁₃ , C ₃₃

3.1.3 Gas category

Tab.2 Gas category, type and supply pressure

Gas category	Gas type	Supply pressure (mbar)
I _{2H}	G20	20

3.1.4 Standards

Codes of Practice — refer to the most recent version

Tab.3 In GB the following Codes of Practice apply:

Standard	Scope
BS 6891	Gas Installation.
BS 5546	Installation of hot water supplies for domestic purposes.
BS EN 12828	Heating systems in buildings.

Standard	Scope
BS EN 12831	Heating systems in buildings — Calculation of load.
BS EN 14336	Installation & commissioning of water based heating systems.
BS 6798	Installation of gas fired hot water boilers.
BS 5440 Part 1	Flues.
BS 5440 Part 2	Ventilation.
BS 7074	Expansion vessels and ancillary equipment for sealed water systems.
BS 7593	Treatment of water in domestic hot water central heating systems.
BS 4814	Specification for Expansion Vessels using an internal diaphragm, for sealed hot water systems.
IGE/UP/7/1998	Guide for gas installations in timber framed housing.

Tab.4 In IE the following Code of Practice apply:

Standard	Scope
IS 813	Domestic Gas Installations.
The following standards give valuable additional information:	
BS 5546	Installation of hot water supplies for domestic purposes.
BS EN 12828	Heating systems in buildings.
BS EN 12831	Heating systems in buildings — Calculation of load.
BS EN 14336	Installation & commissioning of water based heating systems.
BS 7074	Expansion vessels and ancillary equipment for sealed water systems.
BS 7593	Treatment of water in domestic hot water central heating systems.

3.2 Technical data

3.2.1 Technical information



Important

All data in these sections are nominal and subject to normal production tolerances.

Tab.5 General

Main Eco Compact Combi			25	30
Gas council numbers			47 467 14	47 467 15
Nominal heat input domestic hot water — Maximum rate	Net (Qn Hi)	kW	25.8	30.9
	Gross (Qn Hs)	kW	28.6	34.3

Main Eco Compact Combi			25	30
Nominal heat input central heating — Maximum rate	Net (Qn Hi)	kW	20.6	20.6
	Gross (Qn Hs)	kW	22.9	22.9
Nominal heat input — Minimum rate	Net (Qn Hi)	kW	6.2	6.2
	Gross (Qn Hs)	kW	6.9	6.9
Nominal heat output 80/60°C — domestic hot water — Maximum rate	Pn	kW	25	30
Nominal heat output 80/60°C — central heating — Maximum rate	Pn	kW	20	20
Nominal heat output 80/60°C — central heating — Factory setting	Pn	kW	20	20
Nominal heat output 80/60°C — Minimum rate	Pn	kW	6.1	6.1
Nominal heat output 50/30°C — central heating — Maximum rate	Pnc	kW	21.2	21.2
Nominal heat output 50/30°C — central heating — Minimum rate	Pnc	kW	6.7	6.7

Tab.6 Central heating circuit specifications

Main Eco Compact Combi		25	30
Maximum pressure	bar	3	3
Minimum pressure	bar	0.5	0.5
Central heating temperature adjustment ($\pm 5^{\circ}\text{C}$)	$^{\circ}\text{C}$	25 / 80	25 / 80
Expansion vessel water capacity	litres	7.0	7.0
Expansion vessel pre charge pressure	bar	1.0	1.0
Maximum capacity of central heating system	litres	100	100
Primary water content of boiler (unpressurised)	litres	2.5	2.5

Tab.7 Domestic hot water circuit specifications

Main Eco Compact Combi		25	30
Maximum pressure	bar	8	8
Dynamic minimum pressure	bar	0.5	0.5
Minimum working water flow rate ⁽¹⁾	l/min	2.0	2.0
Specific flow rate (D)	l/min	10.2	12.2
Domestic hot water temperature range adjustment $\pm 5^{\circ}\text{C}$	$^{\circ}\text{C}$	35 / 60	35 / 60
Production of domestic hot water with $\Delta T = 30^{\circ}\text{C}$	l/min	12	14.3
Production of domestic hot water with $\Delta T = 35^{\circ}\text{C}$	l/min	10.2	12.2

(1) Where low flow taps or fittings are intended to be used in the DHW system connected to the boiler, it is strongly recommended that the DHW flow rate DOES NOT fall below 2.5 l/min. This will ensure reliable operation of the DHW function.

Tab.8 Characteristics of combustion

Main Eco Compact Combi		25	30
Natural gas rate (G20) Qmax	m ³ /h	2.71	3.26
Natural gas rate (G20) Qmin	m ³ /h	0.67	0.67



Important
Dynamic (nominal) inlet pressure (Natural gas — G20) 20mbar
 with a CV of 37.78 MJ/m³

Tab.9 Electrical specifications

Main Eco Compact Combi		25	30
Nominal electrical power supply voltage	V	230	230
Nominal electrical power supply frequency	Hz	50	50
Nominal power consumption when firing	W	68	68
External fuse rating	Amp	3	3
Internal fuse rating	Amp	F2A H250V	F2A H250V



Important
 Boiler must be connected to an earth supply.

Tab.10 Other specifications

Main Eco Compact Combi		25	30
Degree of protection against humidity (EN 60529)	IP	IPX5D	IPX5D
Dimensions (height / width / depth)	mm	H 700/W 390/D 285	

Tab.11 Connections

Main Eco Compact Combi		25	30
Gas inlet	mm	22	22
Heating flow	mm	22	22
Heating return	mm	22	22
Cold water inlet	mm	15	15
Hot water outlet	mm	15	15
Pressure relief discharge	mm	15	15
Condensate discharge drain plastic waste pipe	mm	21.5	21.5

Tab.12 Clearances

Main Eco Compact Combi		25	30
Above casing	mm	178	178
Below casing (min)	mm	200	200
Front — for servicing	mm	450	450
Front — for operation	mm	5	5
Sides LH	mm	5	5
Sides RH	mm	5	5

Tab.13 Weights

Main Eco Compact Combi		25	30
Packaged boiler	kg	32.2	32.2
Boiler lift weight (dry)	kg	29.2	29.2
Installed weight (dry)	kg	30.2	30.2

Main Eco Compact Combi		25	30
Installed weight when filled with water	kg	32.5	32.5

3.2.2 Technical parameters

Tab.14 Technical parameters for boiler combination heaters

Main Eco Compact Combi			25	30
Condensing boiler			Yes	Yes
Low-temperature boiler ⁽¹⁾			No	No
B1 boiler			No	No
Cogeneration space heater			No	No
Combination heater			Yes	Yes
Rated heat output	P_{rated}	kW	20	20
Useful heat output at rated heat output and high temperature regime ⁽²⁾	P_4	kW	20	20
Useful heat output at 30% of rated heat output and low temperature regime	P_1	kW	6.7	6.7
Seasonal space heating energy efficiency	η_s	%	93	93
Useful efficiency at rated heat output and high temperature regime	η_4	%	88.0	88.0
Useful efficiency at 30% of rated heat output and low temperature regime	η_1	%	97.8	97.8
Auxiliary electricity consumption				
Full load	el_{max}	kW	0.028	0.038
Part load	el_{min}	kW	0.015	0.015
Standby mode	P_{SB}	kW	0.003	0.003
Other items				
Standby heat loss	P_{stby}	kW	0.040	0.040
Ignition burner power consumption	P_{ign}	kW	0	0
Annual energy consumption	Q_{HE}	GJ	62	62
Sound power level, indoors	L_{WA}	dB	48	48
Emissions of nitrogen oxides	NO_x H_s	mg/kWh	31	31
Domestic hot water parameters				
Declared load profile			XL	XL
Daily electricity consumption	Q_{elec}	kWh	0.192	0.196
Annual electricity consumption	AEC	kWh	42	43
Water heating energy efficiency	η_{wh}	%	90	89
Daily fuel consumption	Q_{fuel}	kWh	21.174	21.465
Annual fuel consumption	AFC	GJ	16	17

(1) Low temperature means for condensing boilers 30°C, for low temperature boilers 37°C and for other heaters 50°C return temperature (at heater inlet).

(2) High temperature regime means 60°C return temperature at heater inlet and 80°C feed temperature at heater outlet.



See
The back cover for contact details.

3.3 Dimensions and connections/clearances

Fig.3 Dimensions and connections / clearances

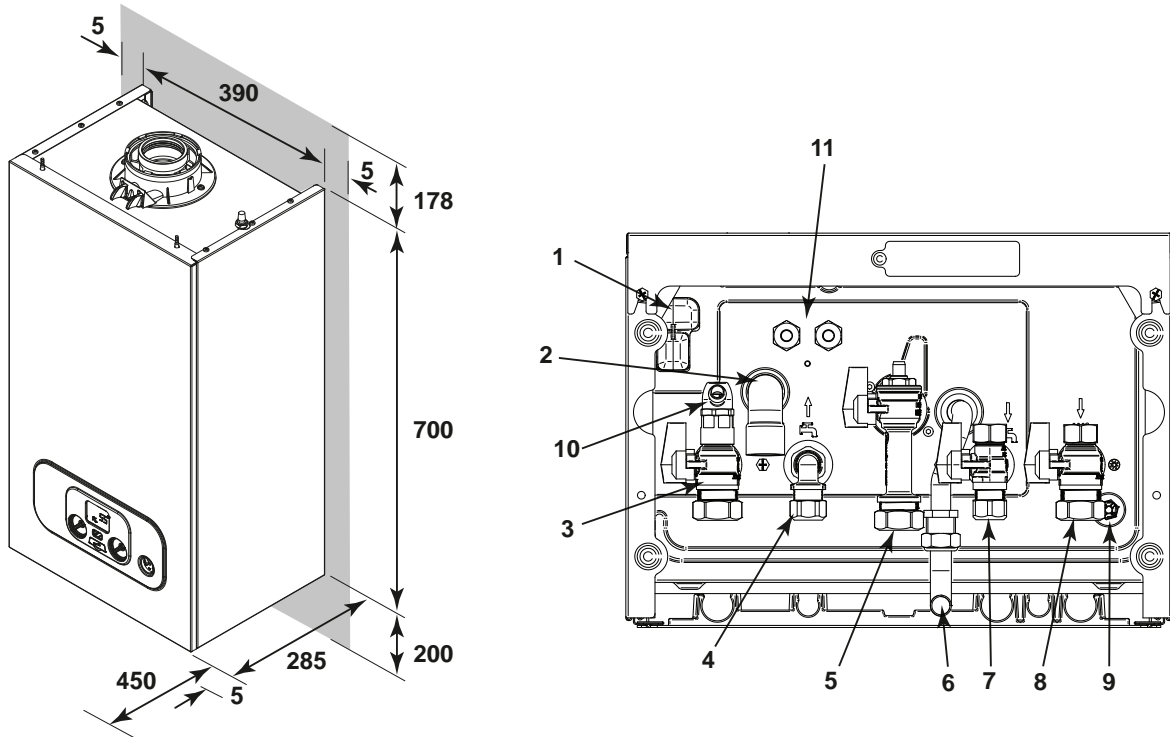

PN-0000338

- 1 Condensate trap sump
- 2 Condensate drain
- 3 Heating circuit water flow
- 4 Hot water outlet
- 5 Gas inlet
- 6 Pressure relief pipe
- 7 Cold water inlet
- 8 Heating circuit water return
- 9 Pump drain point
- 10 Boiler drain point on flow isolation tap
- 11 Cable entry points

The clearances shown in the diagram are minimum requirements to allow for case removal, spanner access and air movement. These should be observed at all times and kept clear of obstructions.

Flue position

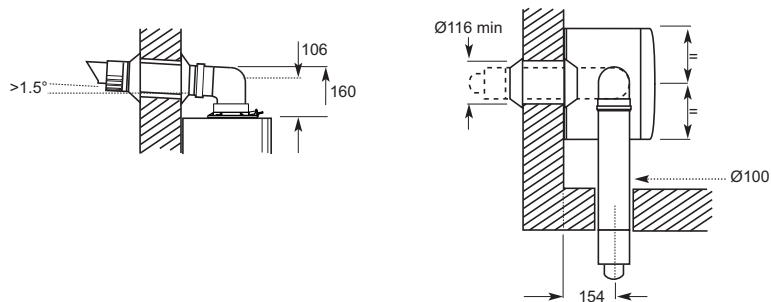

3.4 Electrical diagram

Fig.4 Electrical wiring diagram

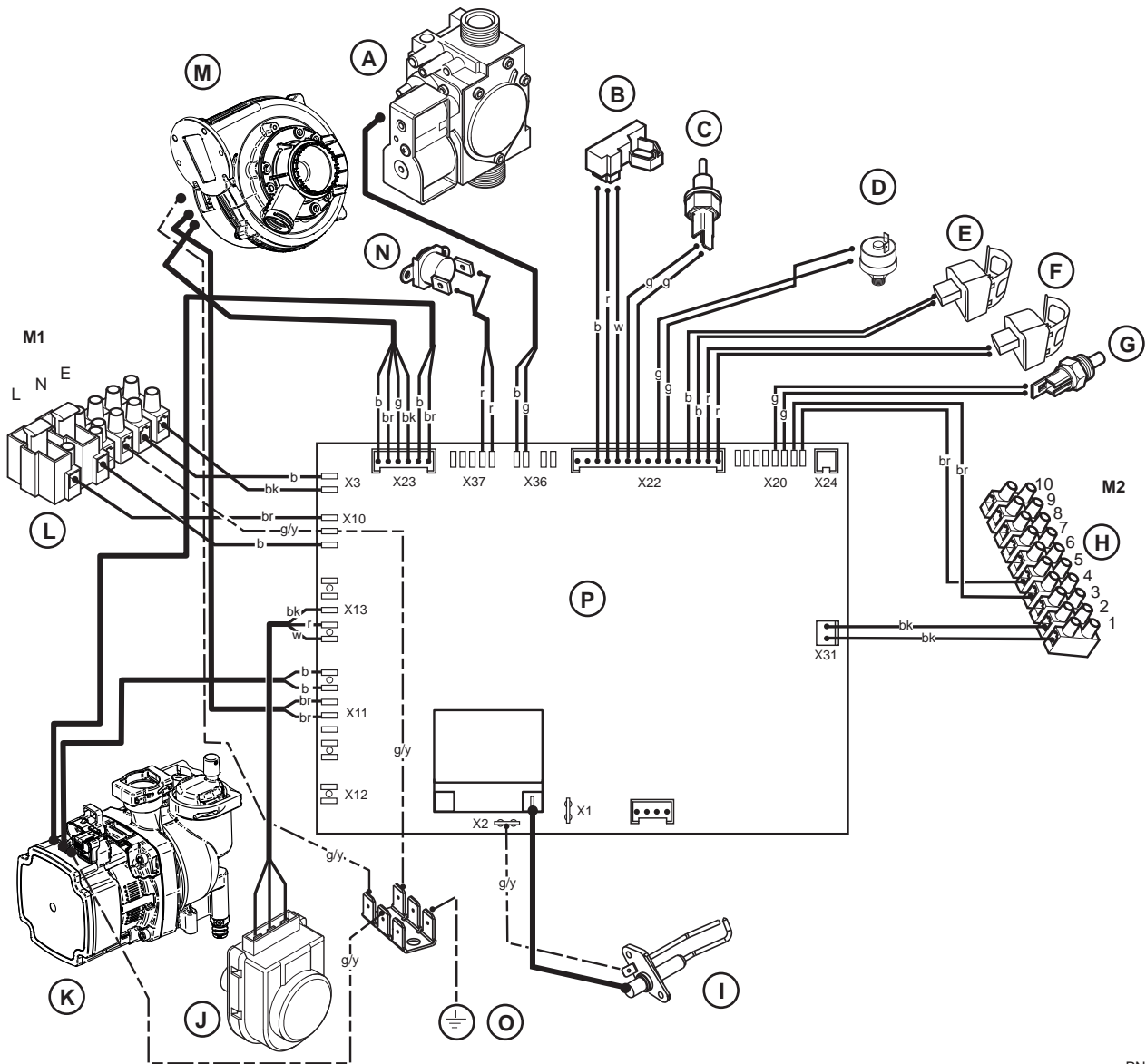

PN-000341

bk — black	br — brown	b — blue	g — green
r — red	w — white	g/y — green/ yellow	

Key	Description	Key	Description
A	Gas valve	I	Spark ignition electrode
B	Hall effect sensor	J	Diverter valve motor
C	Flue sensor	K	Pump
D	Hydraulic pressure switch	L	Terminal strip
E	Heating return sensor	M	Fan
F	Heating flow sensor	N	Safety thermostat
G	DHW NTC sensor	O	Earth point on boiler chassis
H	M2 low voltage external control connection	P	Printed circuit board (PCB)

4 Description of the product

4.1 General description

The Main Eco Compact Combi range are fully automatic gas fired wall mounted condensing boilers. They are room sealed and fan assisted and will serve central heating and mains fed domestic hot water.

Tab.15 The boiler is set to give a maximum output of :-

25 models	25 kW DHW 21.2 kW CH Pnc (Condensing)
30 models	30 kW DHW 21.2 kW CH Pnc (Condensing)

The boiler is factory set for use on Natural Gas (G20).

The boiler is suitable for use only on fully pumped sealed heating systems. Priority is given to domestic hot water.

An information label giving details of the model, serial number and Gas Council number is situated on the front middle underside of the outercase and is accessed by swinging forward gently.

Fig.5 Information label

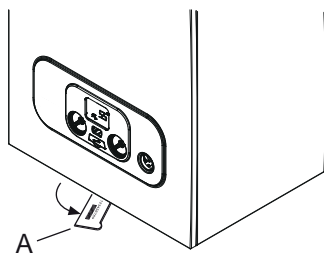

PN-0000368

A Information label

The boiler data badge is positioned on the control box and can be seen when the outercase panel is removed.

The boiler is intended to be installed in residential / domestic environments on a governed meter supply only.

The boiler must be installed with one of the purpose designed flues such as one of the standard horizontal telescopic flue kits detailed in the Flue Accessories and Fitting Guide.

i Important
All systems must be thoroughly cleansed, flushed and treated with inhibitor.

i Note
These installation and servicing instructions must be read in conjunction with the Flue Accessories and Fitting Guide supplied in the literature pack.

4.2 Operating principle

4.2.1 Air-gas adjustment

The air is drawn in by the fan and gas injected directly at the top of the mixer valve. The fan rotation speed is regulated automatically by the electronic board based on temperature adjustment and other parameters. The gas and air are mixed in the manifold. The gas/air ratio ensures that the quantity of gas and air are adjusted correctly to always obtain optimal combustion. The gas/air mixture is fed into the burner at the front of the heat exchanger. The mixture is ignited by the spark electrode.

4.2.2 Combustion

The burner heats the heating water circulating in the heat exchanger. When the temperature of the combustion gas is lower than the dew point (around 55 °C), the water vapour contained in the combustion gas condenses in the flue gas side of the heat exchanger. The heat recovered during this condensation process (the latent heat or condensing heat) is also transferred to the heating water. Once cooled, the combustion gases are discharged through the flue exhaust. The condensed water is discharged through a trap.

4.2.3 Central heating and domestic hot water production

In boilers used for heating and for producing domestic hot water, an integrated plate heat exchanger heats the domestic water. The heated water is then channelled to the heating installation or to the plate heat exchanger via a diverter valve. A flow sensor detects that a hot water tap has been turned on and communicates this to the printed circuit board (PCB), which switches the diverter valve to the hot water position and activates the pump. The diverter valve is spring-loaded but only consumes electricity when switching from one position to another. Priority is given to domestic hot water.

4.2.4 Central heating mode

With a demand for heating the pump circulates water through the primary circuit.

Once the main burner ignites the fan speed controls the gas rate to maintain the heating temperature measured by the temperature sensor.

When the flow temperature exceeds the set temperature, a 3 minute delay occurs before the burner relights automatically (anti-cycling). The pump continues to run during this period.

When the demand is satisfied the burner is extinguished and the pump continues to run for a period of 3 minutes (Pump Overrun).

Key to components

1. Pump with automatic air vent
2. Boiler drain tap
3. Pressure gauge
4. Safety pressure relief valve
5. DHW flow sensor / filter / restrictor
6. DHW priority sensor
7. DHW NTC sensor
8. Hydraulic pressure switch
9. Diverter valve and motor
10. Plate heat exchanger
11. Gas valve
12. Safety thermostat
13. Heating flow sensor
14. Flue sensor
15. Flue adaptor
16. Primary heat exchanger
17. Burner / door assembly
18. Electrode
19. Air / gas collector
20. Heating return sensor
21. Fan
22. Air / gas venturi
23. Expansion vessel

Key to connections

- | | |
|----------|--|
| A | Condensate drain |
| B | Heating flow |
| C | DHW outlet |
| D | Gas inlet |
| E | Cold water inlet on/off valve and filter |
| F | Heating return |

4.2.5 Domestic hot water mode

Priority is given to the domestic hot water supply. A demand at a tap or shower will override any central heating requirement.

The flow of water will operate the Hall Effect Sensor which requests the diverter valve to change position. This will allow the pump to circulate the primary water through the DHW plate heat exchanger.

Fig.6 Operating scheme (combi)

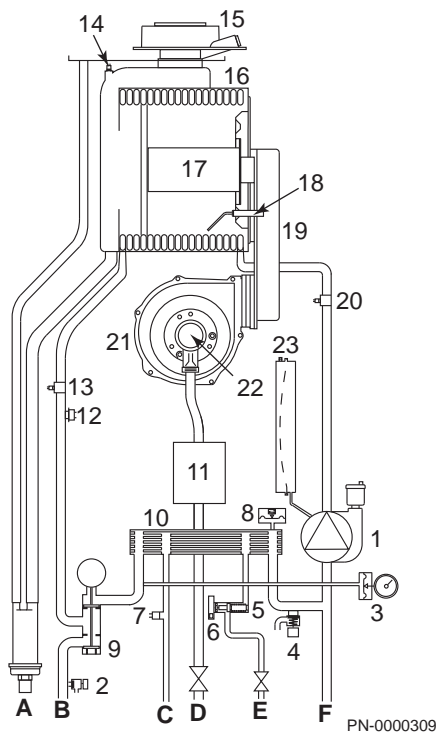

The burner will light automatically and the temperature of domestic hot water is controlled by the temperature sensor.

When the domestic hot water demand ceases the burner will extinguish and the diverter valve will remain in the domestic hot water mode, unless there is a demand for central heating.

4.2.6 Frost protection mode

Where the boiler is sited in an unheated enclosure and during periods when the heating system is to be unused it is recommended that the permanent live is left on to give **boiler frost protection**.

When the boiler temperature falls below 5° C, the boiler will fire until a temperature of 30° C is reached.

Important

This will not protect the system !

Further protection can be incorporated by using a system frost thermostat.

4.2.7 Pump protection

If the boiler has been inactive for a period of 24 hours the pump will automatically operate for 1 minute to prevent sticking.

4.3 Main components

4.3.1 List of components

Fig.7 Component descriptions

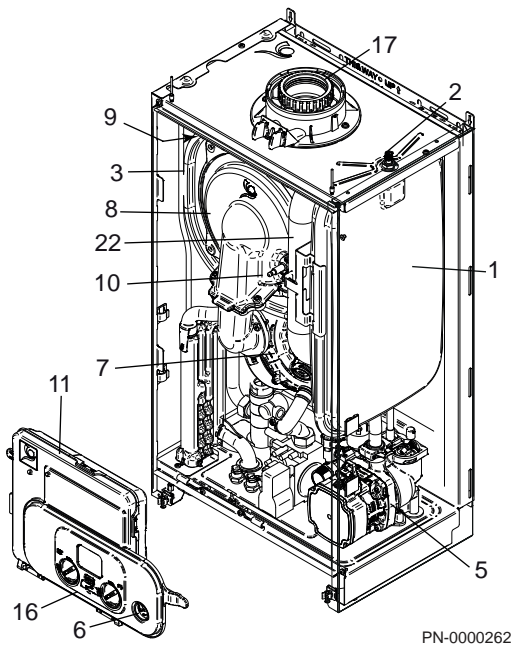

PN-0000262

Fig.8 Hydraulic layout

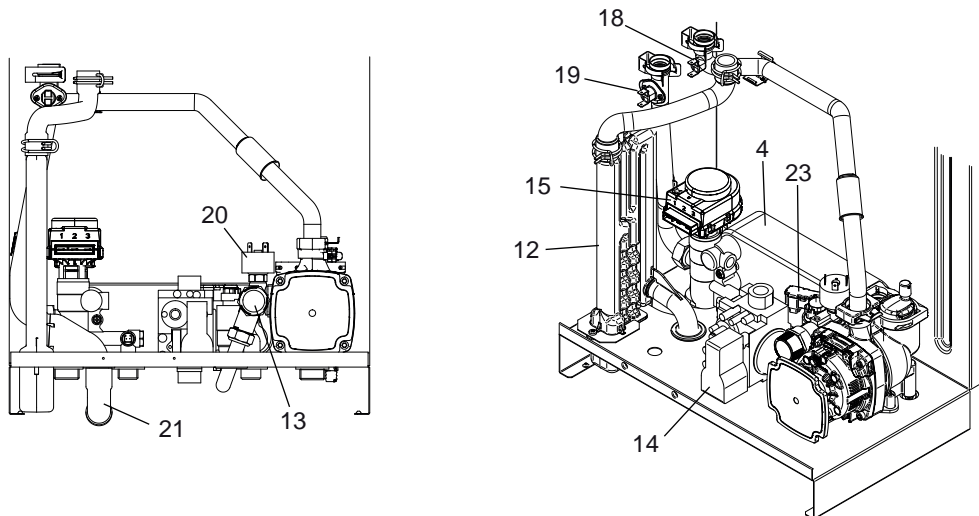

PN-0000388

Tab.16 Component descriptions

Key	Description	Key	Description	Key	Description
1	Expansion vessel	9	Flue sensor	17	Flue adaptor
2	Expansion vessel valve	10	Spark ignition electrode	18	Heating flow sensor
3	Primary heat exchanger	11	Control box	19	Safety thermostat
4	DHW plate heat exchanger (not on System Models)	12	Condensate trap	20	Water Pressure Switch
5	Pump with automatic air vent	13	Safety pressure relief valve	21	Condensate outlet
6	CH system pressure gauge	14	Gas valve	22	Silencer
7	Fan assembly	15	Diverter valve motor (not on System Models)	23	Hall effect sensor (not on System Models)
8	Burner / door assembly	16	Boiler controls		

4.4 Control panel description

Fig.9 Control panel

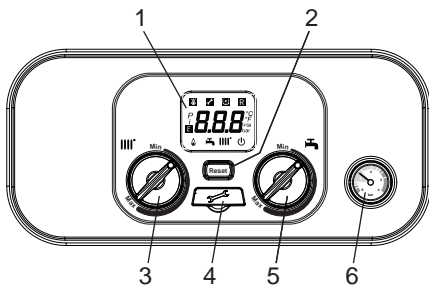

PN-0000334

Fig.10 Display screen

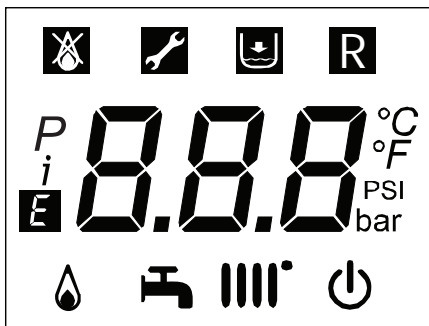

PN-0000336

4.4.1 Description of the control panel

- 1 Display
- 2 Reset button
- 3 Central heating temperature control
- 4 Service diagnostic port
- 5 DHW temperature control
- 6 System water pressure gauge

Display description

The following symbols may be seen on the display

- OFF (frost protection still enabled)
- Indicates errors that prevent the burner from starting
- Error — not resettable by user
- Water pressure too low
- Indicates a resettable error
- P* Not applicable
- i* Not applicable
- Generic error
- Burner lit
- DHW request
- Heating mode
- $^{\circ}\text{C}$ Units for temperature
- $^{\circ}\text{F}$ Units for temperature
- PSI Units for pressure
- bar Units for pressure

4.5 Standard delivery

4.5.1 Contents of the carton

The boiler is delivered in a carton comprising:

- Wall hung gas boiler
- Wall bracket for fastening the boiler to the wall
- Fitting kit, including taps & rigid filling loop (temporary)
- Literature pack containing:

- Installation and service manual
- User guide manual
- Template
- Flue accessories fitting guide
- Warranty documentations
- ErP product and package leaflets
- System additives leaflets

Important

These installation and service instructions **MUST** be read in conjunction with the flue accessories fitting guide supplied in the literature pack.



4.6 Accessories and options

4.6.1 Optional accessories

The table shows the accessories available for this boiler range.

Tab.17 Optional accessories

Part number	Accessory
7212438	Baxi single channel wired programmable room thermostat
720971601	Baxi wired room thermostat
7703233	Baxi on wall outdoor sensor
720648301	Multifit condensate & PRV combined pump
720644401	Multifit 1m condensate drain pipe 'trace heating' element
720664101	Multifit 2m Condensate drain pipe 'trace heating' element
720664201	Multifit 3m condensate drain pipe 'trace Heating' element
720664401	Multifit 5m condensate drain pipe 'trace heating' element
5121379	Multifit remote secondary PRV kit
7665482	Multifit Easy-Fill permanent filling link
7715591	Multifit compact pre-plumbing jig
720971401	Multifit wall mounted 24 hour timeclock
7715535	Main Eco Compact boiler stand off
720030701	Main RF digital 7 day programmable room thermostat
7683084	Baxi IFOS In Flue outdoor sensor
7649277	Baxi uSense wired smart thermostat
7212444	Baxi single channel wired programmer

For flue accessories (elbows, extensions, clamps etc.) refer to the Flue Accessories Fitting Guide supplied in the literature pack.

Any of the above MUST be fitted ONLY by a qualified competent person. Further details can be found in the relevant sales literature and at www.baxi.co.uk

5 Before installation

5.1 Installation regulations



Warning

Installation, repair and maintenance must only be carried out by a competent person. This document is intended for use by competent persons.

Installation must be carried out in accordance with the prevailing regulations, the code of practice and the recommendations in these instructions.

Installation must also respect the following points:

- This instruction manual and any other applicable documentation
- Building Regulations
- British Standards
- Gas Safety Regulations
- Water Supply Regulations

5.2 Installation requirements

5.2.1 Gas supply

The gas installation should be in accordance with the relevant standards. In GB this is BS 6891 (NG). In IE this is the current edition of IS 813 Domestic Gas Installations.

The connection to the appliance is a 22mm copper tail located at the rear of the gas service cock.

Ensure that the pipework from the meter to the appliance is of adequate size, and the demands of any other gas appliances in the property are taken into consideration. Do not use pipes of a smaller diameter than the boiler gas connection (22mm) UNLESS the stated gas rate can be achieved with pipe of lesser diameter and with all other gas appliances operating at maximum rate.

5.2.2 Electrical supply

External wiring must be correctly earthed, polarised and in accordance with relevant regulations/rules. In GB this is the current IEE Wiring Regulations. In IE reference should be made to the current edition of ETCI rules.

The mains supply is 230V ~ 50Hz fused at 3A.

Important

The method of connection to the electricity supply must facilitate complete electrical isolation of the appliance.

Connection may be via a fused double-pole isolator with a contact separation of at least 3mm in all poles and servicing the boiler and system controls only.

The boiler must be connected to the mains fused 3A 230V 50HZ supply & control system using cable of 3 core 0.75mm 3183Y multi strand flexible type.

Important

Any wiring to the boiler, from either the mains or an external control, MUST be cable of the following specification:- 0.75mm 3183/4/5Y (depending on installation) multi strand flexible cable conforming to BS 50525-2-11.

Cable of the above specification is sufficiently flexible to withstand normal regular opening and closing of the fascia/control box as expected during routine servicing and other maintenance work.



Use ONLY cable glands supplied with the boiler, or provided as spares by the manufacturer.

Under no circumstances must solid core cable be used as it is not intended for applications where movement may occur. The use of solid core cable could result in situations potentially hazardous to health.

These points must be considered when initially wiring the boiler to the installation, and if replacing any wiring during the service life of the boiler.

5.2.3 Hard water area

Important

Only water that has NOT been artificially softened must be used when filling or re-pressurising the primary system. If the mains cold water to the property is fitted with an artificial softening/treatment device the source utilised to fill or re-pressurise the system must be upstream of such a device.

5.2.4 Bypass



The boiler utilises the primary side of the DHW plate heat exchanger as an automatic integral bypass.

5.2.5 System control

Further external controls (e.g. room thermostat sensors) MUST be fitted to optimise the economical operation of the boiler in accordance with Part L of the Building Regulations. A range of optional controls is available. Full details are contained in the relevant Sales Literature.

Any proprietary OpenTherm control MUST allow individual adjustment of CH and DHW temperature.

5.2.6 Treatment of water circulating systems

All recirculatory water systems will be subject to corrosion unless an appropriate water treatment is applied. This means that the efficiency of the system will deteriorate as corrosion sludge accumulates within the system, risking damage to pump and valves, boiler noise and circulation problems.

When fitting new systems flux will be evident within the system, which can lead to damage of system components.

BS 7593 gives extensive recommendations on system cleansing and water treatment.

All systems must be thoroughly drained and flushed out using appropriate proprietary flushing agent.

A suitable inhibitor must then be added to the system.

All system additives (flushing agents, cleansers, inhibitors etc.) must comply with the requirements of BS 7593. Full instructions are supplied with the products and for further information contact the additive manufacturer directly or consult their website.

Important

Failure to flush and add inhibitor to the system will invalidate the appliance warranty.

It is important to check the inhibitor concentration after installation, system modification and at every service in accordance with the inhibitor manufacturer. (Test kits are available from inhibitor stockists.)

For information or advice regarding any of the above contact Baxi Customer Support 0344 871 1545.

5.2.7 Showers

If a shower control is supplied from the appliance it should be of the thermostatic or pressure balanced type. Thermostatic type shower valves provide the best comfort and guard against water at too high a temperature. Existing controls may not be suitable - refer to the shower valve manufacturer.

5.2.8 Expansion vessel (CH only)

The appliance expansion vessel is pre-charged to 1.0 bar. Therefore, the minimum cold fill pressure is 1.0 bar. The vessel is suitable for correct operation for system capacities up to 100 litres. For greater system capacities an additional expansion vessel must be fitted.

For GB refer to BS 7074 Pt 1. For IE, the current edition of IS 813 Domestic Gas Installations.

Checking the charge pressure of the vessel - to check the charge accurately ensure the system is cold. It is also necessary to relieve the pressure by draining the boiler. Using a suitable gauge check the pressure at the valve on the underside of the vessel. Adjust the pressure as required and repressurise the system.

5.2.9 Safety pressure relief valve

- 1 Discharge pipe
- 2 Pressure relief valve
- A The end of the pipe should terminate facing down and towards the wall



See
BS 6798 for full details.

The pressure relief valve is set at 3 bar, therefore all pipework, fittings, etc. should be suitable for pressures in excess of 3 bar and temperature in excess of 100°C.

The pressure relief discharge pipe should be not less than 15mm diameter, run continuously downward, and discharge outside the building, preferably over a drain. It should be routed in such a manner that no hazard occurs to occupants or causes damage to wiring or electrical components. If it is anticipated that any part of the pipe may be subject to freezing it should be suitably insulated. The end of the pipe should terminate facing down and towards the wall.

The discharge must not be above a window, entrance or other public access. Consideration must be given to the possibility that boiling water/steam could discharge from the pipe.

Important

The relief valve must never be used to drain the system.

A remote relief valve kit is available to enable the boiler to be installed in cellars or similar locations below outside ground level.

Fig.11 Discharge pipe

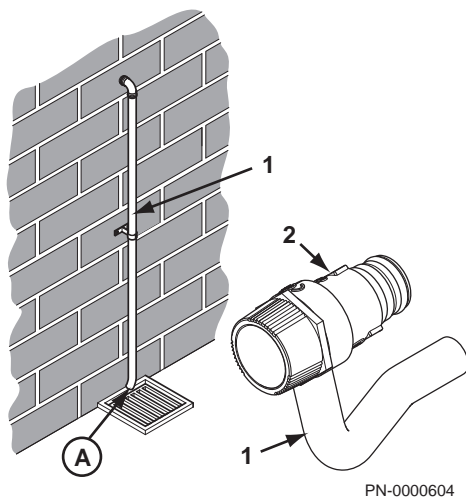

A boiler discharge pump is available which will dispose of both condensate & high temperature water from the relief valve. It has a maximum head of 5 metres.

5.3 Choice of the location

5.3.1 Location of the boiler

The boiler may be fitted to any suitable wall with the flue passing through an outside wall or roof and discharging to atmosphere in a position permitting satisfactory removal of combustion products and providing an adequate air supply. The boiler should be fitted within the building unless otherwise protected by a suitable enclosure i.e. garage or outhouse. (The boiler may be fitted inside a cupboard.)

Where the boiler is sited in an unheated enclosure and during periods when the heating system is to be unused it is recommended that the permanent live is left on to give BOILER frost protection. **NOTE: THIS WILL NOT PROTECT THE SYSTEM !**

If the boiler is fitted in a room containing a bath or shower reference must be made to the relevant requirements.

In GB this is the current IEE Wiring Regulations and Building Regulations.

In IE reference should be made to the current edition of IS 813 Domestic Gas Installations and the current ETCI rules.

If the boiler is to be fitted into a building of timber frame construction then reference must be made to the current edition of Institute of Gas Engineers Publication IGE/UP/7 (Gas Installations in Timber Framed Housing).

Fig.12 Bathroom 1 and 2

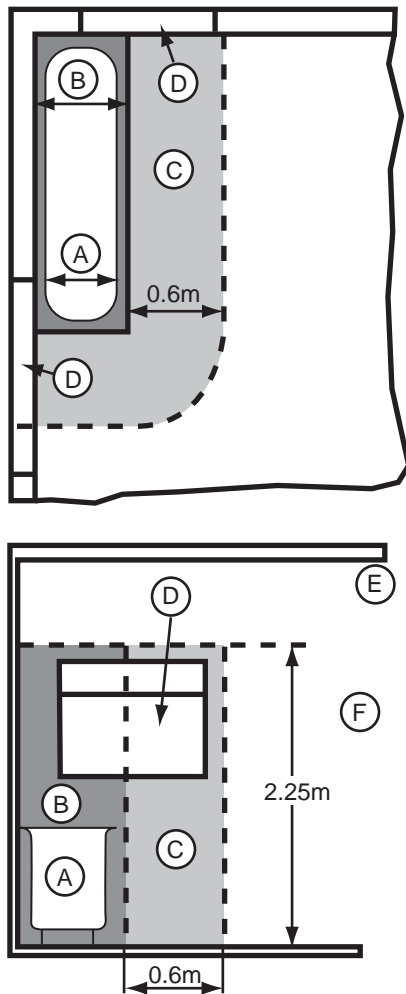

PN-0000400

5.3.2 Bath and shower rooms

- A Zone 0
- B Zone 1
- C Zone 2
- D Window recess Zone 2
- E Ceiling
- F Outside zones

Important

The boiler has a protection rating of IPX5D and if installed in a room containing a bath or shower can be within Zone 2 (but not 0 or 1).

Bathroom 1 and 2 (in GB only) shows zone dimensions for a bathtub. For other examples refer to the Current IEE Wiring Regulations). Reference must be made to the relevant requirements.

1

In GB this is the current IEE. Wiring Regulations and Building Regulations.

In IE reference should be made to the current edition of IS 813 "Domestic Gas Installations" and the current ETCI rules.

i

5.3.3 Ventilation

Where the appliance is installed in a cupboard or compartment, no air vents are required. BS 5440: Part 2 refers to room sealed appliances installed in compartments. The appliance will run sufficiently cool without ventilation.

Fig.13 Pipework and method of termination

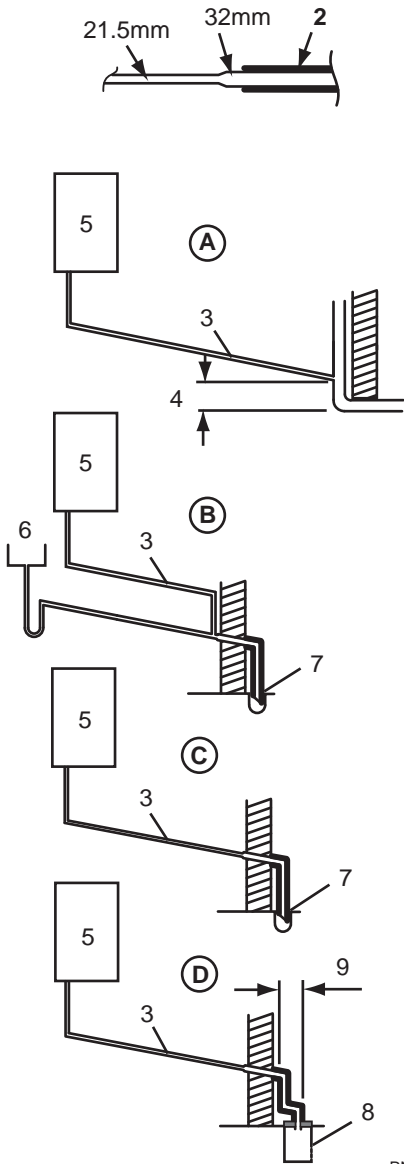

PN-0000389

5.3.4 Condensate drain

It is strongly recommended to discharge internally into the household drainage system. If connecting to a rain water drain, that drain MUST discharge into a foul drain.

- 1 Pipework.
- 2 Insulation.
- 3 50mm per metre of pipe run — 2.5° minimum run.
- 4 450mm minimum is applicable to properties up to 3 storeys. For multi-storey building installations consult BS 6798.
- 5 Boiler.
- 6 Sink.
- 7 Pipe must terminate above water level but below surrounding surface. Cut end at 45°.
- 8 Holes in the soak-away must face away from the building.
- 9 500mm minimum.
- 10 Basement or similar (heated)
- 11 Condensate pump
- 12 Unheated Location (e.g. Garage)

Tab.18 Examples are shown of the following methods of termination

Key	Description
A	Termination to an internal soil and vent pipe.
B	External termination via internal discharge branch e.g. sink waste — downstream (It is NOT RECOMMENDED to connect upstream of the sink or other waste water receptacle!)
C	Termination to a drain or gully.
D	Termination to a purpose made soakaway Further specific requirements for soakaway design are referred to in BS 6798
E	Pumped into an internal discharge branch (e.g. sink waste) downstream of the trap.
F	Pumped into an external soil and vent pipe.
G	Termination to a drain or gully with extended external run and trace heating. The "Trace Heating" element must be installed in accordance with the instructions supplied. External runs and those in unheated locations still require insulation.

Fig.14 Methods of termination continued

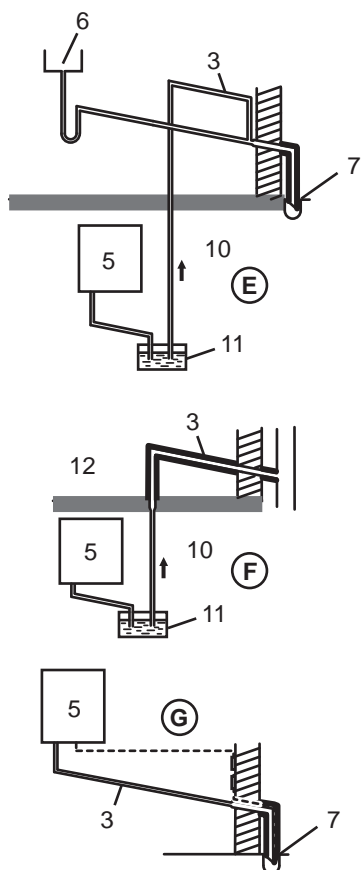

PN-0000455

Important

Failure to install the condensate discharge pipework correctly will affect the reliable operation of the boiler.

Careful consideration must be given to the possibility of the pipework being subject to freezing conditions and appropriate measures taken to prevent blockage. Correct installation in accordance with this section will considerably minimise the likelihood of blockage and subsequent boiler lock-out.

i

A condensate discharge pump and pipe "Trace Heating" are available as accessories.

The condensate discharge pipe **MUST NOT RISE** at any point along its length. There **MUST** be a fall of **AT LEAST 2.5°** (50mm per metre) along the entire run **EXCEPT** when employing a suitable condensate pump in basement and cellar or similar applications.

The boiler condensate trap incorporates a seal of 75mm, therefore it is unnecessary to install an air break and trap in the discharge pipework.

The condensate outlet will accept 21.5mm ($\frac{3}{4}$ in) plastic overflow pipe. **It is strongly recommended that this discharges internally into the household drainage system.** Where this is not possible, discharge into an outside drain is permissible providing every possible precaution is taken to prevent freezing.

Ensure the discharge of condensate complies with any national or local regulations in force. **BS 6798 & Part H1 of the Building Regulations give further detailed guidance.**

The discharge pipe should be run in a proprietary drain pipe material e.g. PVC, PVC-U, ABS, PVC-C or PP.

Metal pipework is **NOT** suitable for use in condensate discharge systems.

The pipe should be a minimum of 21.5mm diameter and must be supported using suitably spaced clips of the correct design to prevent sagging.

It is advisable that the full length of condensate pipe is run internally and preferably be less than 3 metres.

Internal runs greater than 3 metres or runs in cold areas should use 32mm waste pipe.

External runs MUST be a MINIMUM of 32mm and fully insulated with material suitable for external use.

If the boiler is fitted in an unheated location the entire condensate discharge pipe should be treated as an external run and sized and insulated accordingly.

In all cases discharge pipe must be installed to aid disposal of the condensate. To reduce the risk of condensate being trapped, as few bends and fittings as possible should be used and any burrs on cut pipe removed.

When discharging condensate into a soil stack or waste pipe the effects of existing plumbing must be considered. If soil pipes or waste pipes are subjected to internal pressure fluctuations when WC's are flushed or sinks emptied then backpressure may force water out of the boiler trap and cause appliance lockout.

A boiler discharge pump is available which will dispose of both condensate & high temperature water from the relief valve. It has a maximum head of 5 metres. Follow the instructions supplied with the pump.

Condensate Drain Pipe "Trace Heating" Elements are available in various lengths, 1, 2, 3 & 5 metres. Where the drain is between 3 & 5 metres a 5 metre kit can be used and "doubled back" upon itself.

It is possible to fit the element externally on the condensate drain or internally as detailed in the instructions provided.

The fitting of a "Trace Heating" Element is **NOT** a substitute for correct installation of the condensate drain. **ALL** requirements in this section must still be adhered to.

5.3.5 Clearances

Fig.15 Clearances

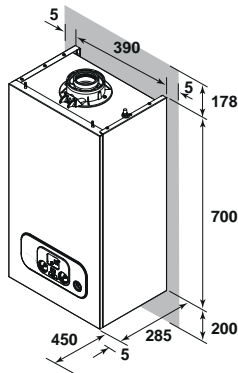

PN-0000344

A flat vertical area is required for the installation of the boiler and it should be capable of bearing the weight of the boiler when full of water.

These dimensions include the necessary clearances around the boiler for case removal, spanner access and air movement. Additional clearances may be required for the passage of pipes around local obstructions such as joists running parallel to the front face of the boiler.

In the diagram these are MINIMUM recommended dimensions. Greater clearance will aid installation and maintenance.

5.3.6 Flue/chimney location

The following guidelines indicate the general requirements for siting balanced flue terminals. For GB recommendations are given in BS 5440 Pt 1. For IE recommendations are given in the current edition of I.S. 813 Domestic Gas Installations.

Important

Due to the nature of the boiler a plume of water vapour will be discharged from the flue. This should be taken into account when siting the flue terminal.

Fig.16 Flue outlets

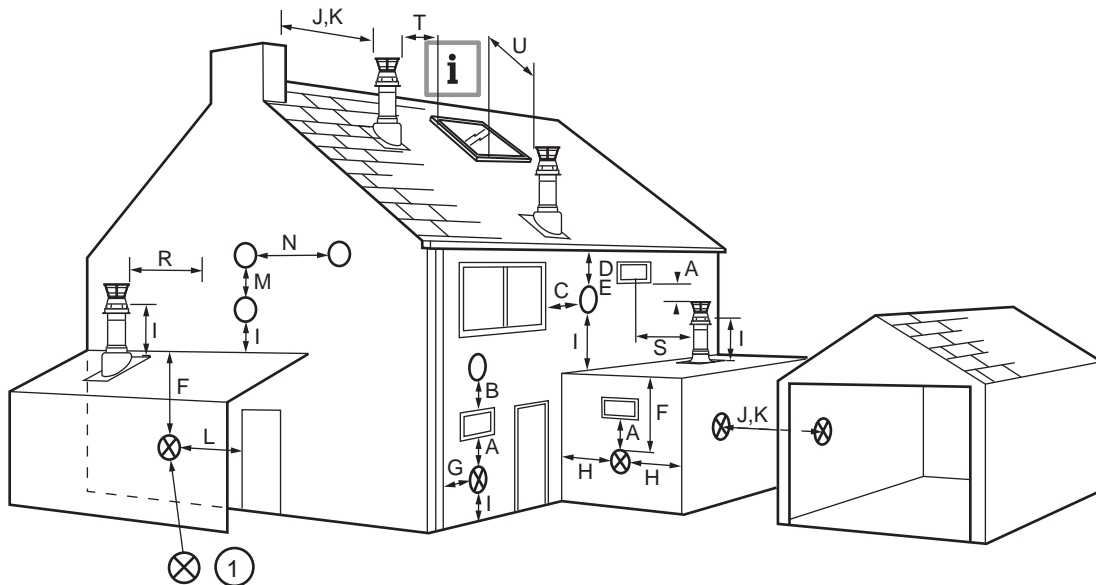

PN-0000456

1 Flue positions marked ⊗ require a flue terminal guard.

Tab.19 Terminal position with minimum distance

Key	Description	mm	Key	Description	mm
A ⁽¹⁾	Directly below an opening, air brick opening window etc.	300	J	From a surface or boundary line facing a terminal	600
B ⁽¹⁾	Above an opening, air brick, opening window etc.	300	K	From a terminal facing a terminal (Horizontal flue)	1200
				From a terminal facing a terminal (Vertical flue)	600

Key	Description	mm	Key	Description	mm
C ⁽¹⁾	Horizontally to an opening, air brick, opening window etc.	300	L	From an opening in carport (e.g. door, window) into the dwelling	1200
D ⁽²⁾	Below gutters, soil pipes or drain pipes	25 (75)	M	Vertically from a terminal on the same wall	1500
E ⁽²⁾	Below eaves	25 (200)	N	Horizontally from a terminal on the same wall	300
F ⁽²⁾	Below balconies or car port roof	25 (200)	R	From adjacent wall to flue (vertical only)	300
G ⁽²⁾	From a vertical drain pipe or soil pipe	25 (150)	S	From an adjacent opening window (vertical only)	1000
H ⁽²⁾	From an internal or external corner	25 (300)	T	Adjacent to windows or openings on pitched and flat roofs	600
I	Above ground, roof, or balcony level	300	U	Below windows or openings on pitched roofs	2000

(1) In addition, the terminal should be no nearer than 150mm to an opening in the building fabric formed for the purpose of accommodating a built-in element such as a window frame.

(2) Only ONE 25mm clearance is allowed per installation. If one of the dimension D,E,F,G or H is 25mm then the remainder MUST be as shown in brackets, in accordance with BS 5440-1.

Important

Under car ports we recommend the use of the plume displacement kit. The terminal position must ensure the safe and nuisance-free dispersal of combustion products.

If the terminal discharges onto a pathway or passageway, check that combustion products will not cause a nuisance and that the terminal will not obstruct the passageway.

If a terminal is less than 2 metres above a balcony, above ground or above a flat roof to which people have access, then a suitable terminal guard must be provided.

Fig.17 Property boundary

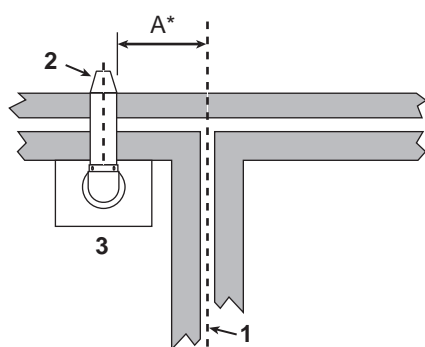

PN-0000457

- 1 Property boundary line
- 2 Terminal assembly
- 3 Top view rear flue
- A 300mm minimum*

*Reduction to the boundary is possible down to 25mm but the flue deflector must be used.

Important

The distance from a fanned draught appliance terminal installed parallel to a boundary may not be less than 300mm in accordance with the diagram opposite.



Fig.18 Plume displacement kit

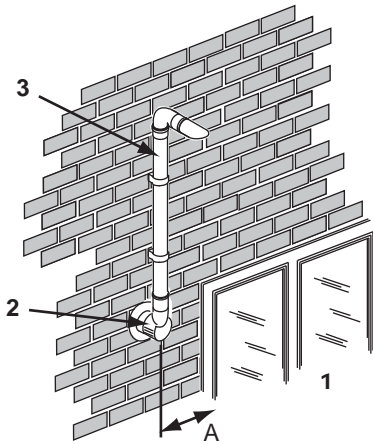

PN-0000458

- 1 Opening window or door
- 2 Air inlet
- 3 Plume displacement kit
- A 150mm minimum

Important

If fitting a Plume Displacement Flue Kit, the air inlet must be a minimum of 150mm from any opening windows or doors.

Important

The Plume Displacement flue gas discharge terminal and air inlet must always terminate in the same pressure zone i.e. on the same facing wall.



5.3.7 Horizontal flue/chimney systems

Fig.19 Horizontal flues

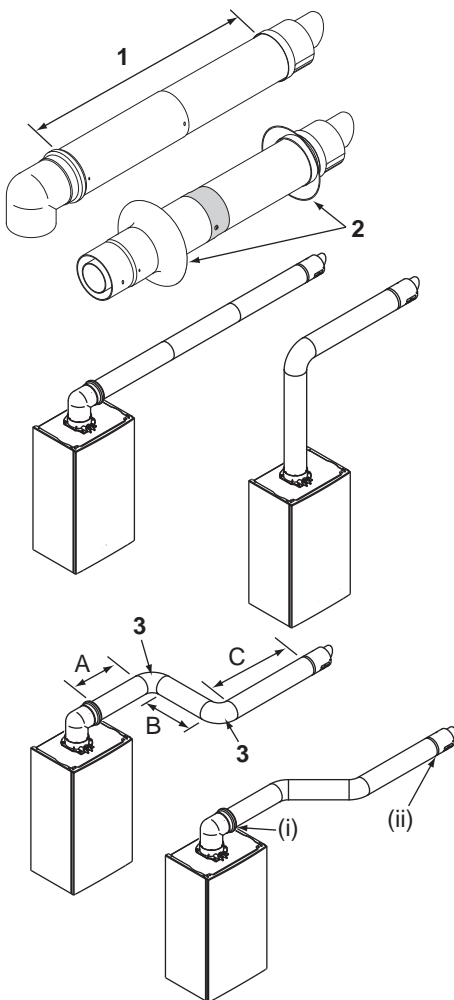

PN-0000459

- 1 315mm to 500mm
- 2 Flue trims
- 3 This bend is equivalent to 1 metre

Total equivalent length = A+B+C+2x90° bends

Important

Horizontal flue extensions should always be installed with a fall of at least 1.5° from the terminal to allow condensate to run back to the boiler.

The standard telescopic flue is suitable only for horizontal termination applications. It allows for lengths between 315mm and 500mm from elbow to terminal without the need for cutting. Extensions of 250mm, 500mm and 1m are available.

All fittings should be fully engaged. The approximate engagement is 40mm. Apply the lubricant supplied to the seal on each fitting to aid assembly.

Tab.20 Maximum permissible equivalent flue lengths are:-

Horizontal concentric	60/100 Diameter	80/125 Diameter
	10 metres	20 metres

Any additional "in line" bends in the flue system must be taken into consideration.

Tab.21 Their equivalent lengths are:-

Concentric pipes	135° bend	0.5 metres
	93° bend	1.0 metres

The elbow supplied with the standard horizontal telescopic flue kit is not included in any equivalent length calculations.

Important

Flue length is measured from point (i) to (ii) as shown.



See

Read this section in conjunction with the Flue Installation Guide supplied with the boiler. This document includes details of vertical flue/chimney systems and plume displacement kits.



**Warning**

SUPPORT - All flue systems MUST be securely supported at a MINIMUM of once every metre & every change of direction. It is recommended that every straight piece is supported irrespective of length. Additional supports are available as accessories.

VOIDS - Consideration must be given to flue systems in voids and the provision of adequate access for subsequent periodic visual inspection.

Fig.20 Flexible flue trims

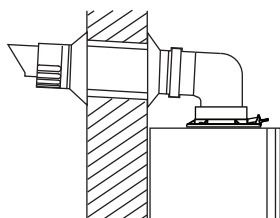

PN-0000390

5.3.8 Flue/chimney trim

The flexible flue trims supplied can be fitted on the outer and inner faces of the wall of installation.

Fig.21 Terminal guard

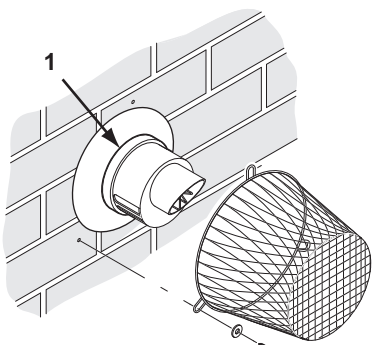

PN-0000460

5.3.9 Terminal guard

- ENSURE THAT NO PART OF THE WHITE OUTER CHIMNEY DUCT IS VISIBLE.**

When codes of practice dictate the use of terminal guards Multifit accessory part no. 720627901 can be used

Important

This guard is not compatible with Flue Deflector referred to below.

There must be a clearance of at least 50mm between any part of the terminal and the guard.

When ordering a terminal guard, quote the appliance name and model number.

The flue terminal guard should be positioned centrally over the terminal and fixed as illustrated.

5.3.10 Flue/chimney deflector

Fig.22 Flue deflector

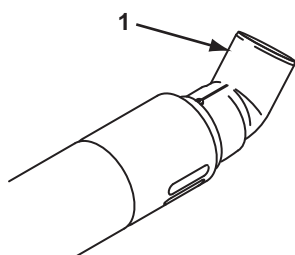

PN-0000461

- Flue deflector

Push the flue deflector over the terminal end. It may point upwards as shown, or up to 45° either way from vertical. Secure the deflector to the terminal with screws provided.

5.3.11 Flue/chimney accessories**See**

For full details of Flue Accessories (elbows, extensions, clamps etc.) refer to the Flue Installation Guide supplied in the literature pack.

5.4 Transport

This product should be lifted and handled by two people. When lifting always keep your back straight and wear protective equipment where nec-

essary. Carrying and lifting equipment should be used as required. e.g. when installing in a loft.

5.5 Unpacking & initial preparation

Fig.23 Unpacking the boiler

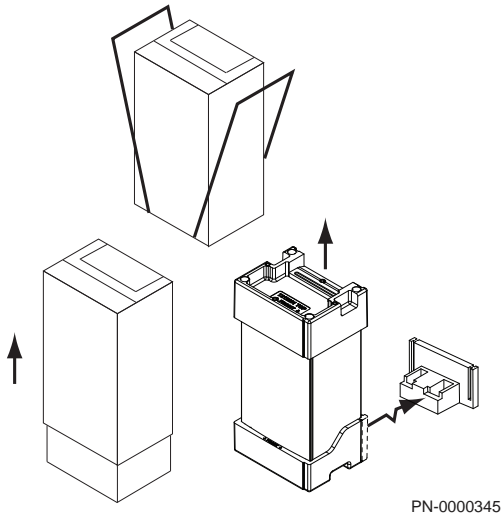

5.5.1 Unpacking



Caution

RISK ASSESSMENT - Before commencing the installation it is recommended that the "Five Steps to Risk Assessment" document published by the HSE is consulted, and an assessment performed as described. **GAS SUPPLY** - The gas supply, gas type and pressure must be checked for suitability before connection.



See

Handling, page 9 before unpacking or lifting the boiler.

To unpack the boiler:

1. Remove the banding and the cardboard sleeve.
2. Remove the polystyrene top piece and installation kit.
3. Snap off the rear part of the polystyrene bottom piece.

Important

Polystyrene base should be removed completely if fitting the boiler into a space with minimum side clearances of 5 mm each side.

Important

If removing the polystyrene base, the sealing caps can also be removed at this stage. **Care must be taken to avoid damage from any residual water in the boiler.**



5.5.2 Initial preparation



1. After considering the site requirements position the fixing template on the wall ensuring it is level both horizontally and vertically.
2. Mark the position of the two most suitable fixing slots for the wall plate.
3. Mark the position of the centre of the flue hole (rear exit). For side flue exit, mark as shown.
4. If required, mark the position of the gas and water pipes. Remove the template.
5. Cut the hole for the flue (minimum diameter 116mm).
6. Drill the wall as previously marked to accept the wall plugs supplied. Secure the wall plate using the fixing screws.
7. Using a spirit level ensure that the plate is level before finally tightening the screws.

Fig.24 Template

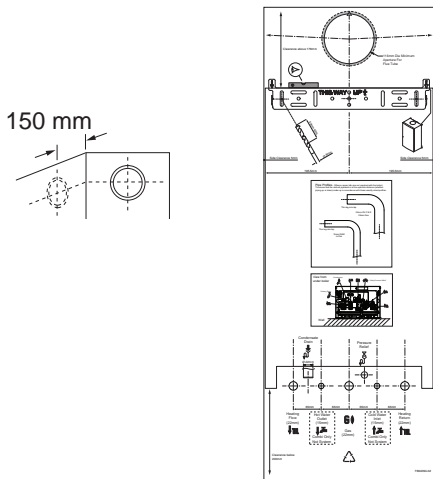

5.6 Connecting diagrams

Fig.25 System filling circuit

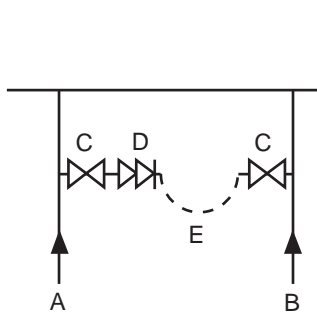

PN-0000347

5.6.1 Filling information

- A Domestic hot water mains inlet
- B Central heating return
- C Stop valve
- D Double check valve (Not supplied)
- E Loop (Temporary or Permanent)

A filling point connection on the central heating return pipework must be provided to facilitate initial filling and pressurising and also any subsequent water loss replacement/refilling.

The filling method adopted must be in accordance with all relevant water supply regulations and use approved equipment.

Your attention is drawn to:

for GB: Guidance G24.2 and recommendation R24.2 of the Water Regulations Guide.

for IE: the current edition of I.S. 813 Domestic Gas Installations.

- A Cold mains in
- B Heat return

The sealed primary circuits may be filled or replenished by means of a temporary connection between the circuit and a supply pipe, provided a "Listed" double check valve or some other no less effective backflow prevention device is permanently connected at the inlet to the circuit and the temporary connection is removed after use.

When the optional permanent filling link is fitted it is not necessary to remove any part of it after filling or re-pressurising.

Fig.26 Circuit plan

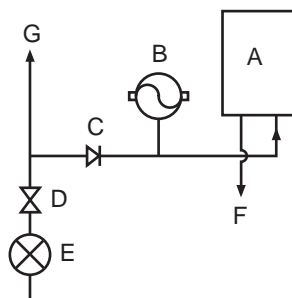

PN-0000350

5.6.2 Domestic hot water circuit

- A Boiler
- B Expansion vessel
- C Check valve
- D Pressure reducer
- E Stop tap
- F To hot tap
- G Other tap outlets

All DHW circuits, connections, fittings, etc. should be fully in accordance with relevant standards and water supply regulations.

Your attention is drawn to:

for GB: Guidance G17 to G24 and recommendation R17 to R24 of the Water Regulations Guide.

for IE: the current edition of IS 813 Domestic Gas Installations.

The Water Regulations recommendations for England and Wales prohibits backflow from appliances into the wholesome water supply due to thermal expansion. However this type of instantaneous combination boiler, with less than 15 litres of stored capacity, does not require any backflow prevention device as any thermal expansion is accommodated within the appliance. It is possible in certain circumstances that other cold water demands (e.g. washing machines, flushing of WCs) may affect the DHW function of the boiler. In these instances the fitting of a backflow prevention device and expansion vessel is recommended.

i **Important**

In instances where the mains water supply incorporates a non-return backflow prevention device, or any other device that includes one*, it is possible for a build-up of pressure to occur. This may result in damage to the boiler and other appliances. To prevent damage to the boiler it is strongly recommended that a suitable mini expansion vessel is fitted on the mains water inlet between the boiler and the non-return device.

*(The manufacturer of the device should be consulted if there is any doubt regarding the presence of a non-return feature).

Even in circumstances where a non-return device is not fitted any future modifications to the mains inlet (e.g. fitting of a water meter) should be considered and an expansion vessel fitted. Main cannot accept any responsibility for damage to the boiler if these recommendations are not followed.

The boiler's maximum working mains pressure is 8 bar, therefore all pipe-work, connections, fittings, etc. should be suitable for pressures in excess of 8 bar. A pressure reducing valve must be fitted for pressures in excess of 8 bar. The manufacturer of any outlet fittings, such as a shower valve, may require a lower maximum pressure. The pressure reduction must take account of all fittings connected to the DHW system.

6 Installation

6.1 General

Fig.27 Mounting the boiler

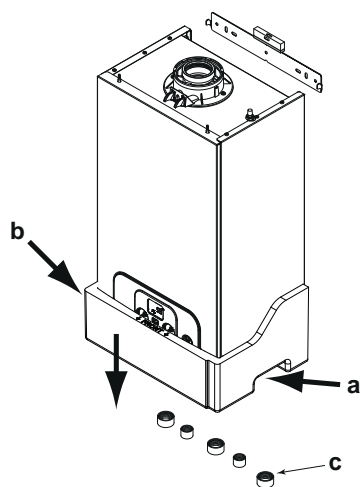

PN-0000306

Fig.28 Connecting the taps

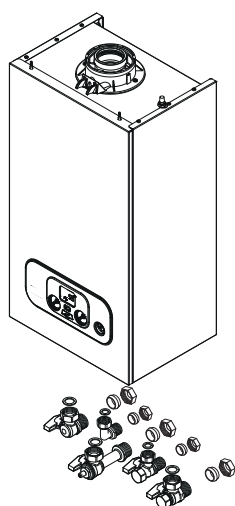

PN-0000307

Installation must be carried out in accordance with the prevailing regulations, codes of practice and the recommendations in this manual.



Danger

If the boiler is installed in a compartment do not use it for storage purposes. Do not obstruct any purpose provided ventilation openings.



Caution

Where the boiler is sited in an unheated enclosure provision must be made to protect against frost, e.g. frost thermostat, pipe thermostat.

1. Lift the boiler by gripping "a" and "b" and hook the boiler onto the wall plate.
2. Remove the polystyrene bottom piece by slipping it off downwards.

3. Remove the sealing caps from the boiler connections under the boiler (including the condensate trap).

c Sealing caps



Warning

Some residual water may escape when removing the sealing caps. Take precautions to avoid damage to components !

4. Remove the taps, elbow and sealing washers from the fitting kit. The taps and elbow accept 15mm or 22mm copper pipe as appropriate — see template.
5. Connect the appropriate tap to the heating flow and return pipework, gas supply and mains cold inlet.
6. Connect the elbow to the DHW flow outlet.
7. Using the sealing washers provided connect the taps and elbow to the boiler.
8. Ensure all joints are tight.

Important

Connect the pressure relief discharge pipe first before any other pipework.

6.2 Assembly

Fig.29 Pressure relief pipe connection

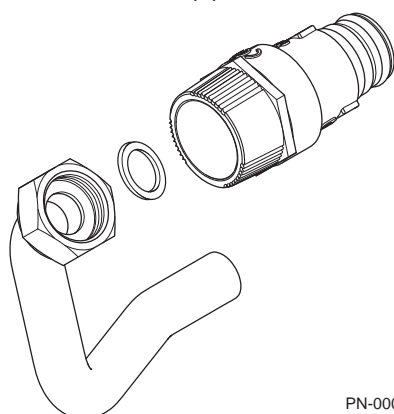

PN-0000603

6.2.1 Fitting the pressure relief discharge pipe



1. Remove the discharge pipe from the kit.
2. Determine the routing of the discharge pipe in the vicinity of the boiler. Make up as much of the pipework as is practical, including the discharge pipe supplied.

Important

Make all soldered joints before connecting to the pressure relief valve. Do not adjust the position of the valve. The discharge pipe must be installed before pressurising the system.

3. The pipework must be at least 15mm diameter and run continuously downwards to a discharge point outside the building.
4. Firmly engage the flange on the pipe into the pressure relief valve outlet grommet, ensuring it is pushed fully in.



Complete the discharge pipework and route it to the outside discharge point.

Fig.30 Pour 300ml of water into flue spigot

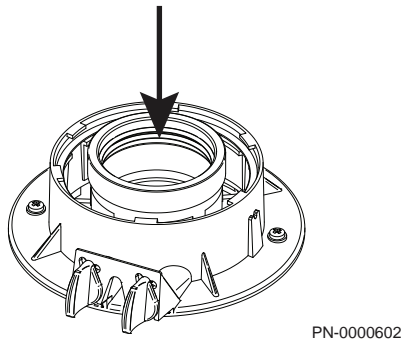

- The pipework must be clipped at suitable intervals to support it, commencing as close to the boiler as possible.

6.2.2 Connecting the condensate drain

- Remove the blanking cap, and using the straight rubber coupling supplied, connect the condensate drain pipework to the boiler condensate trap outlet pipe.



See

Ensure the discharge of condensate complies with any national or local regulations in force (see HHIC recommendations).



See

Condensate drain, page 30.

- The straight rubber coupling will accept 21.5mm (³/₄ in) plastic overflow pipe which should generally discharge internally into the household drainage system. If this is not possible, discharge into an outside drain is acceptable.

Important

The boiler condensate trap should be primed by pouring approximately 300ml of water into the flue spigot. Do not allow any water to fall into the air inlet.

6.3 Air supply/flue gas connections

Fig.31 Telescopic flue

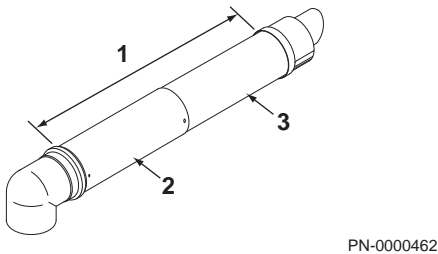

6.3.1 Connecting the flue/chimney

HORIZONTAL TELESCOPIC FLUE (concentric 60/100)

- 315mm to 500mm
- Connection assembly
- Terminal assembly

There are two telescopic sections, the terminal assembly and the connection assembly, a roll of sealing tape and two self tapping screws. A 93° elbow is also supplied.

The two sections can be adjusted to provide a length between 315mm and 500mm when measured from the flue elbow (there is 40mm engagement into the elbow).

- Locate the flue elbow on the adaptor at the top of the boiler. Set the elbow to the required orientation.

Important

The flue elbow is angled at 93° to ensure a fall back to the boiler.

Fig.32 Flue dimension X

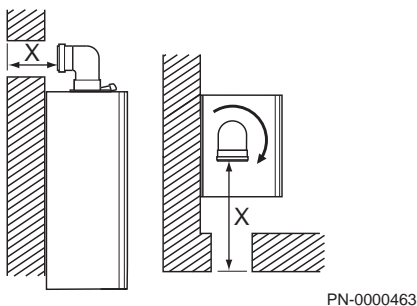

In instances where the dimension "X" is between 250mm and 315mm it will be necessary to shorten the terminal assembly by careful cutting to accommodate walls of these thicknesses.

Fig.33 Flue dimension Y

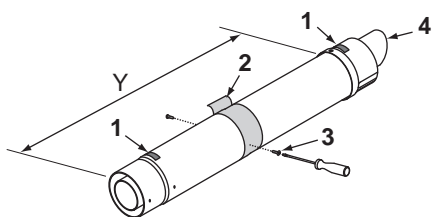

PN-0000464

Fig.34 Attaching the flue

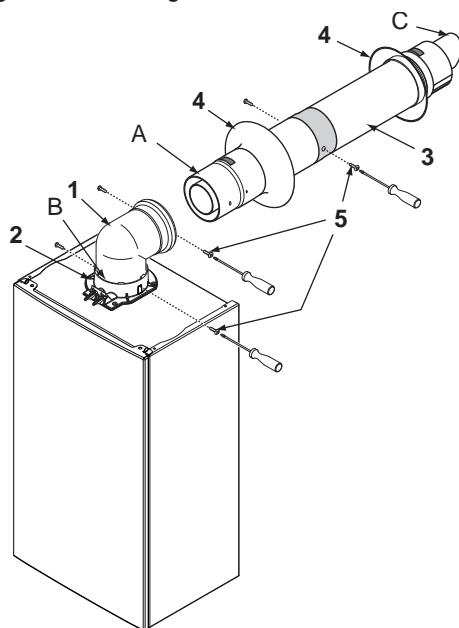

PN-0000465

5. To dimension "X" add 40mm. This dimension to be known as "Y" .
 - 1 TOP label
 - 2 Sealing tape
 - 3 Securing screw
 - 4 Peak to be uppermost
6. Adjust the two telescopic sections to dimension "Y" and seal the joint with the tape provided. Ensure that the labels marked "TOP" on the terminal and connection assemblies are uppermost.
7. Using the clearance holes in the connection assembly secure it to the terminal assembly using the screws supplied with the telescopic flue.
8. Remove the flue elbow and insert the flue through the hole in the wall. Fit the flue trims if required, and refit the elbow to the boiler adaptor, ensuring that it is pushed fully in. Secure the elbow with the screws supplied in the boiler fitting kit.
 - 1 Flue elbow
 - 2 Boiler adaptor
 - 3 Telescopic flue
 - 4 Flue trim
 - 5 Securing screw
 - A Apply the lubricant supplied for ease of assembly (**do not use any other type**). Ensure flue is fully engaged into elbow.
 - B Apply the lubricant supplied for ease of assembly (**do not use any other type**). Ensure elbow is fully engaged into boiler adaptor.
 - C Peak to be uppermost
9. Draw the flue back through the wall and engage it in the elbow. It may be necessary to lubricate to ease assembly of the elbow and flue.
10. Ensure that the terminal is positioned with the slots to the bottom. Secure to the elbow with the screws supplied with the telescopic flue.

Important

It is essential that the flue terminal is fitted as shown to ensure correct boiler operation and prevent water entering the flue.

11. Make good between the wall and air duct outside the building, appropriate to the wall construction and fire rating.
12. If necessary fit a terminal guard.

**Important**

There must be no part of the air duct (white tube) visible outside the property.



6.4 Electrical connections



See
Electrical supply, page 25 for details of the electrical supply.



Warning
Check that the total nominal consumption of the accessories connected to the appliance is less than 1 amp. If it is higher, a relay must be installed between the accessories and the electronic board.

6.4.1 Making the electrical connection

Fig.35 Remove terminal cover

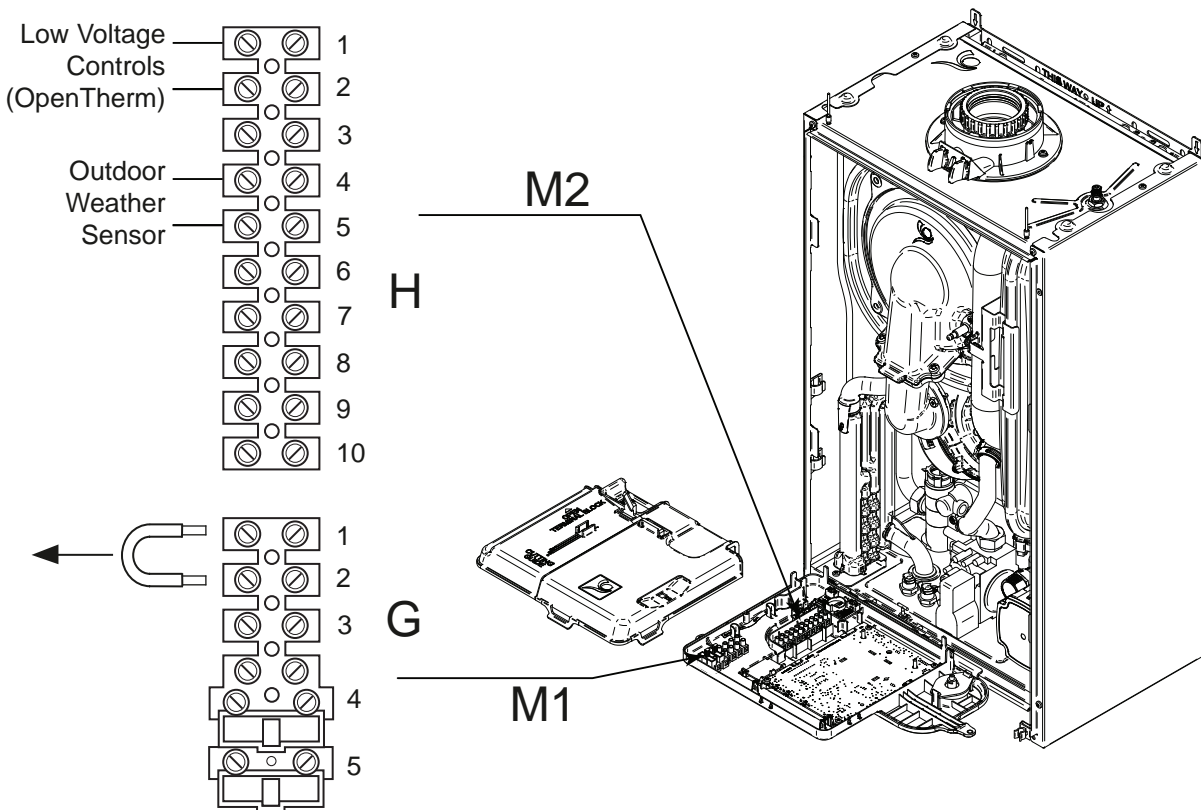

PN-000395

Important

When fitting external controls remove the yellow link wire from the Mains Terminal Block M1.

Note

Consideration must be given to Health and Safety Document 635 (The Electricity at Work Regulations, 1989).



1. Remove the front panel.



See
Specific maintenance instructions, page 57 to remove the front panel.



2. Hinge down the control box and unclip the terminal block cover.
3. Slacken both gland nuts in the bottom of the boiler lower panel and insert the mains cable and the external control system cable through them.
4. Leave sufficient slack in the cables to allow the control box to be hinged fully open. Tighten both gland nuts.

Fig.36 Typical electrical connections

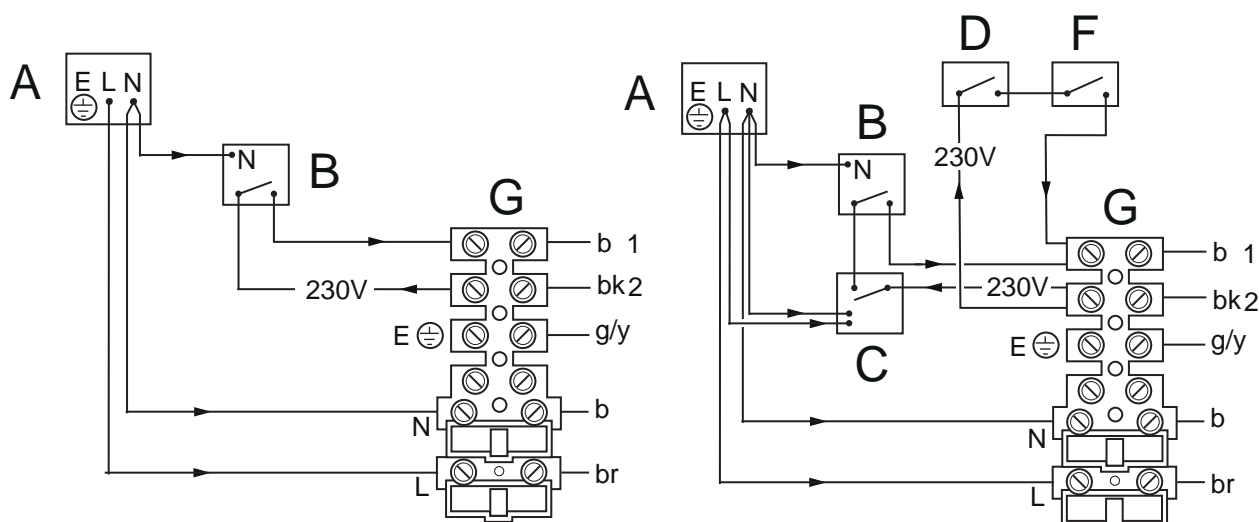

PN-0000396

5. Connect the earth, permanent live and neutral wires to the terminal block.

Note

Both the permanent live and neutral connections are fused.

Key	Description	Key	Description
A	Fused Spur	b	Blue
B	Room Thermostat	bk	Black
C	External Clock	br	Brown
D	Frost Thermostat	g/y	Green/Yellow
F	Pipe Thermostat	E	Earth
G	Mains Terminal Block M1	N	Neutral
H	Low Voltage Terminal Block M2	L	Live

6. Refer to the instructions supplied with the external control(s).
7. Remove the link between terminals 1 and 2.
8. The 230V supply at terminal 2 must be connected to the thermostat.
9. The switched output from the thermostat must connect to terminal 1.

Important

The 230V switched signal for external controls (frost thermostat — room thermostat — timer) must always be taken from terminal 2 at the boiler. Live, Neutral and Earth to power these controls must be taken from the Fused Spur.

10. Reclip the terminal block cover back into position and hinge back the control box.

**Important**

When an OpenTherm controller is connected adjustment of the boiler, e.g. heating temperature, is made using the OpenTherm controller rather than the boiler controls. The boiler controls are overridden by the OpenTherm control. Please check the functionality with the manufacturer of the OpenTherm controller.

Preliminary electrical checks

Prior to commissioning the boiler preliminary electrical system checks should be carried out.

These should be performed using a suitable meter, and include checks for Earth Continuity, Resistance to Earth, Short Circuit and Polarity.

6.4.2 Connecting on wall outdoor sensor

Fig.37 Sensor position

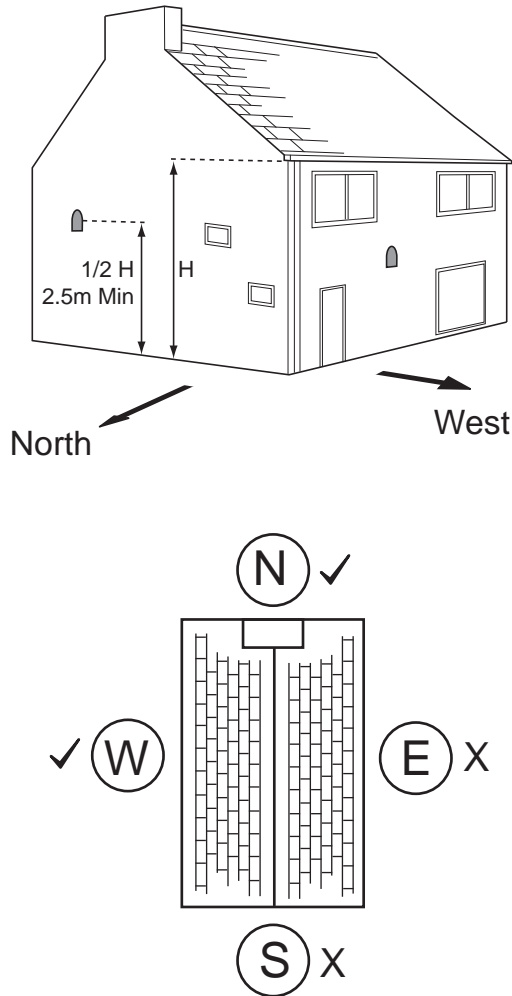

PN-0000626

The sensor must be fixed to an external wall surface of the property it is serving. The wall must face north or west. Under no circumstance must it be fixed to a south facing wall in direct sunlight.

The sensor must be positioned approximately at half the height of the living space of the property, and a minimum of at least 2.5 metres above ground level.

To ensure accurate operation do not position the sensor in the proximity of any heat or cooling source (e.g. a flue terminal). Siting above doors & windows, adjacent to vents and close to eaves should be avoided.

1. Once the position has been determined, prise the cover off the sensor and mark through the sensor body the two fixing holes and the larger hole for the wiring.
2. Drill & plug the two fixing holes (plugs and screws are supplied with the sensor). Also drill the hole for the sensor wiring.
3. Insert the sensor wiring through the hole in the wall, leaving sufficient length outside to allow connection. Seal the hole. **Note: 0.5mm 2 core cable is recommended** (the sensor is a low voltage device). This wiring is NOT supplied in the kit.
4. If it is not possible to pass the wiring through the wall directly behind, remove the circular 'knock-out' panel in the sensor base to allow connection.
5. Using the screws provided fit the body to the wall. Insert the wires in the two-way terminal block and secure them. Replace the sensor cover.
6. Ensure the electrical supply to the boiler is isolated and remove the front panel.
7. Hinge down the control box and unclip the terminal block cover.
8. Pass the wires from the sensor through one of the gland nuts in the bottom of the boiler lower panel, leaving sufficient slack to allow the control box to be hinged fully open. Tighten the nut.
9. Connect the wires from the sensor to positions 4 & 5 of low voltage terminal block M2. Refit the cover and front panel.
10. Reinststate the electrical supply to the boiler.
11. From the graph determine which is the most appropriate curve for the installation and the expectations of the user. For example if curve 50 is selected, at an outside temperature of 10°C the boiler flow temperature will be 65°C. In the event of the outside temperature falling to 0°C the boiler flow will increase to 85°C.

Connecting Baxi IFOS in flue outdoor sensor

Please refer to the instructions supplied with the kit.

6.4.3 Identifying label

Important

The identifying label (7221476-01) supplied with the outdoor sensor must be signed and affixed on or adjacent to the boiler. The label must be readily accessible without removing the boiler casing or any other disassembly. This label is required to enable SAP and energy assessors to identify that a weather compensation device is installed and connected.

6.4.4

Outdoor sensor graph

Fig.38 Graph showing available curves

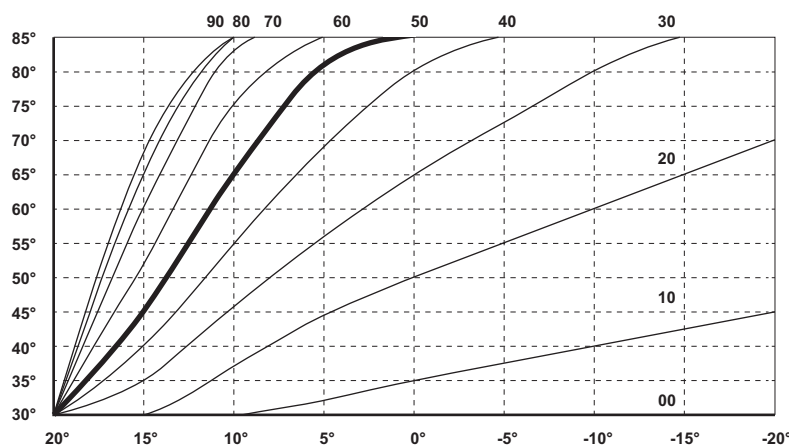

PN-0000627

There are 9 available curves. It is essential that expected outdoor temperatures and the user requirements are considered before selecting the curve.

Boiler flow temperature is shown on the vertical axis. The outside temperature is along the horizontal axis.

6.4.5 Setting outdoor sensor curve

Fig.39 Control knob and setting curve

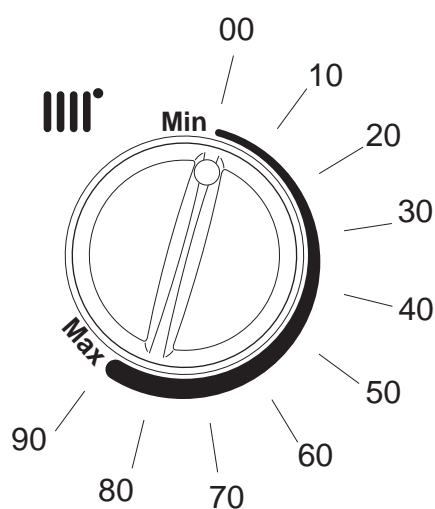

PN-0000628

1. Ensure that there is power to the boiler (though it is not necessary for there to be any heating demand).
2. The central heating control knob should be turned clockwise to the position which corresponds with the desired curve as shown on the graph.
3. Curve 50 is recommended as the most suitable for the normal range of conditions expected in the UK. Consider the type of dwelling and discuss with the user their requirements — one of the other curves may be more appropriate.
4. Normally the display will show the current temperature of the water in the boiler. As the knob is turned the display will show the selected curve.
5. Once the curve is set the installation and commissioning of the boiler can be completed.

Note

Explain to the user how to select a different temperature curve and how the outdoor sensor regulates the boiler flow temperature.

Important

When an OpenTherm controller is connected adjustment of the boiler, e.g. heating temperature, is made using the OpenTherm controller rather than the boiler controls. The boiler controls are overridden by the OpenTherm control. Please check the functionality with the manufacturer of the OpenTherm controller.

i

Fig.40 Example — setting to curve 50

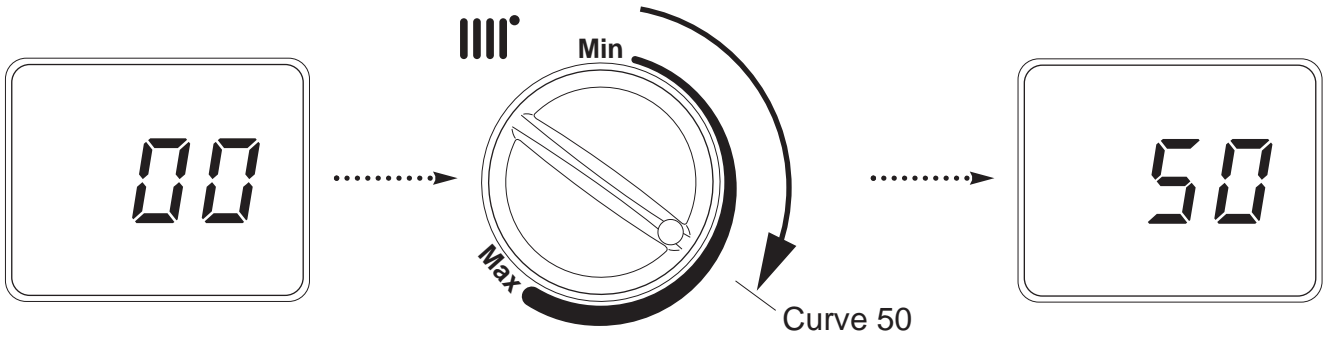

PN-0000629

6.5 Filling the installation

6.5.1 Flushing the system

Flush thoroughly and treat the system according to guidance given in BS 7593.

6.5.2 Fill the installation

A filling point connection on the central heating return pipework must be provided to facilitate initial filling and pressurising and also any subsequent water loss replacement/refilling.

1. Fill the installation using approved equipment and in accordance with all relevant water supply regulations.

Important

Your attention is drawn to:

for GB: Guidance G24.2 and recommendation R24.2 of the Water Regulations Guide.

for IE: the current edition of I.S. 813 "Domestic Gas Installations".

- i 2. The sealed primary circuits may be filled or replenished by means of a temporary connection between the circuit and a supply pipe, provided a 'Listed' double check valve or some other no less effective backflow prevention device is permanently connected at the inlet to the circuit and the temporary connection is removed after use.
3. Fill or replenish the sealed primary circuits by means of a temporary connection between the circuit and a supply pipe:
 - Permanently connect a 'Listed' double check valve or some other no less effective backflow prevention device at the inlet to the circuit.
 - Remove the temporary connection after use except if where a permanent connection is used.

6.5.3 Filling the condensate trap

1. Check that the boiler condensate trap has been primed before commissioning the boiler.

7 Commissioning

7.1 General

Reference should be made to BS:EN 12828, 12831 & 14336 when commissioning the boiler. Ensure that the condensate drain trap has been primed.

At the time of commissioning, complete all relevant sections of the Benchmark Checklist at the rear of this publication.

Open the mains water supply to the boiler and all hot water taps to purge the DHW system.

Ensure that the filling loop is connected and open, then open the heating flow and return valves on the boiler. Ensure that the cap on the automatic air vent on the pump body is opened.

The system must be flushed in accordance with BS 7593 and the flushing agent manufacturer's instructions.

Pressurise the system to 1.5 bar then close and disconnect the temporary filling loop except where a permanent loop is fitted.

Test for gas tightness, turn the gas supply on and purge according to GB BS 6891 and in IE I.S. 813 "Domestic Gas Installations" .

7.2 Checklist before commissioning

7.2.1 Preliminary electrical checks

Note

Consideration must be given to Health & Safety Document 635 (The Electricity at Work Regulations, 1989).

Prior to commissioning the boiler preliminary electrical system checks should be carried out.

These should be performed using a suitable meter, and include checks for Earth Continuity, Resistance to Earth, Short Circuit and Polarity.



7.2.2 Checks

Checked:

- That the boiler has been installed in accordance with these instructions.
- The integrity of the flue system and the flue seals.
- The integrity of the boiler combustion circuit and the relevant seals.
- That the condensate trap has been primed.

7.3 Commissioning procedure

Fig.41 Setting de-aeration

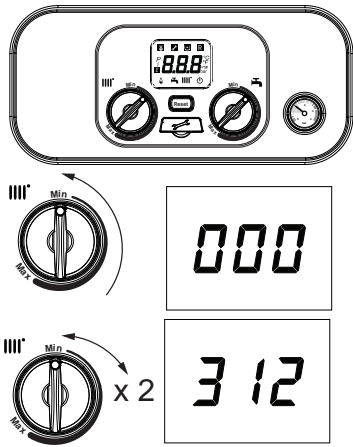

PN-0000360

7.3.1 De-Aeration function

Before turning on the power to the boiler, rotate the CH control knob (III) fully anticlockwise.

The purpose of the function is to remove as much air as possible from the heating system. To assist this it is essential that all precautions are taken to remove air manually before enabling the function. Ensure that all radiators are fully bled, starting on the lowest floor in properties of more than one storey. Any high points in the system should be fitted with a suitable venting device. On the boiler's first power up de-aeration lasts approximately 7 minutes. The boiler will not operate during this process.

1. Turn on the power to the boiler. The display shows "000" .
2. Turn the CH control knob (III) 1/4 turn clockwise twice in quick succession (within 2 seconds).
3. Display shows "312" while de-aeration is taking place (approximately 7 minutes).
4. When de-aeration has completed, the display will show the primary flow temperature and both the CH (III) and DHW (II) symbols.

Important

If during the first commissioning process the power to the boiler is interrupted the de-aeration function will re-start automatically at the point which it stopped once power is restored.



Caution

If the system is drained in the future (even partly, when replacing a radiator for example) the de-aeration function must be repeated. Also the inhibitor concentration must be checked and replenished if necessary.

7.4 Gas settings

Fig.42 Gas meter to valve

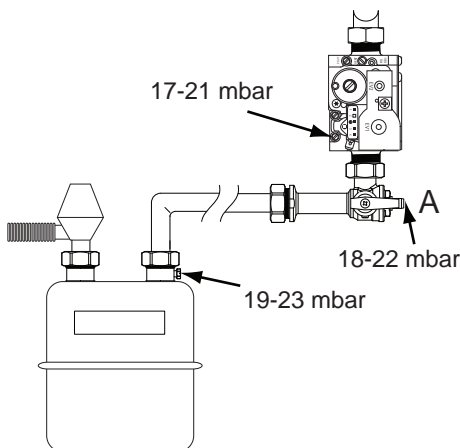

PN-0000361

7.4.1 Check the operational (working gas inlet pressure and gas rate)

Note

If the pressure drops are greater than shown in the diagram opposite, a problem with the pipework or connections is indicated. Permissible pressure drop across system pipework ≤ 1mbar. Carry out chimney sweep.



See

Checking combustion - chimney sweep mode, page 49.

Fig.43 Gas inlet test point

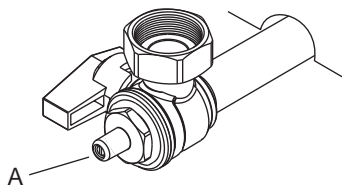

PN-0000362

1. With the boiler operating in the maximum rate condition check that the operational (working) gas pressure at the inlet gas pressure test point is in accordance with BS 6798 & BS 6891. This must be AT LEAST 18mb !
2. Ensure that this inlet pressure can be obtained with all other gas appliances in the property working. The pressure should be measured at the gas test point on the gas inlet (A).
3. **Measure the gas rate**— With any other appliances & pilot lights turned OFF the gas rate can be measured. It should be:-
Tab.22 Natural gas

25 model	2.71 m ³ /h
30 model	3.26 m ³ /h

7.4.2 Checking combustion - chimney sweep mode

Fig.44 Flue adaptor test points

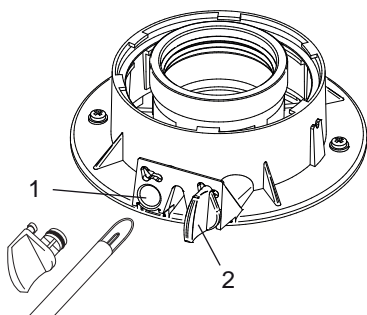

PN-0000363

- The case front panel must be fitted when checking combustion.
- Ensure the system is cold and the gas and electric supplies are turned on.



Important

The person carrying out a combustion measurement should have been assessed as competent in the use of a flue gas analyser and the interpretation of the results.

- 1 Combustion test point
- 2 Incoming air for combustion test point



Important

Allow the combustion to stabilise before inserting the Combustion Analyser Probe into the Test Point (1). This will prevent saturation of the analyser.

The combustion must be measured and recorded at the Maximum and Minimum heat inputs.

Fig.45 Setting chimney sweep mode

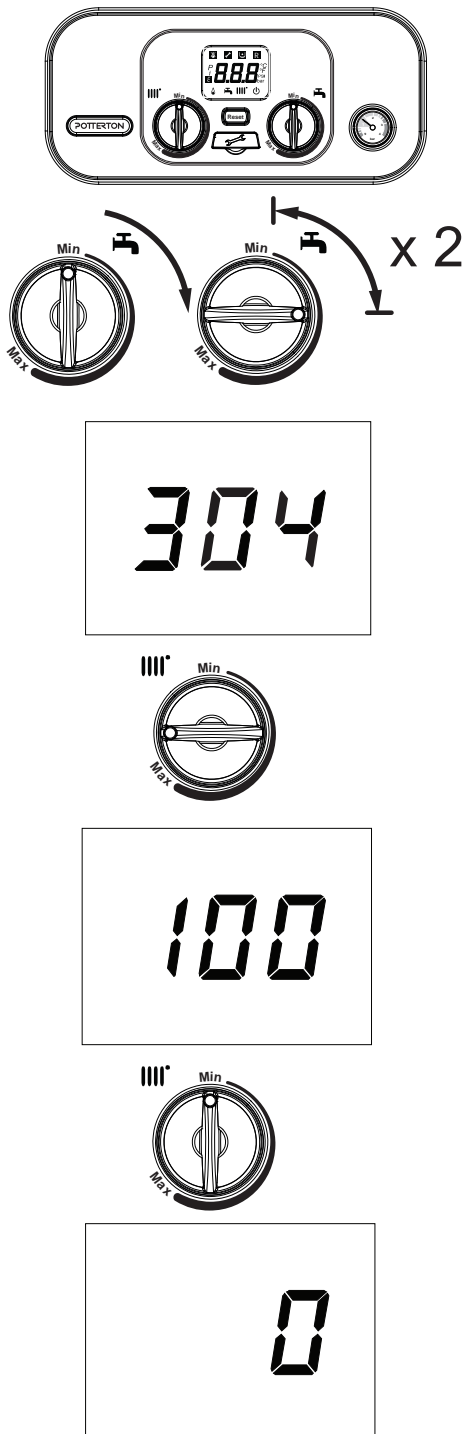
**Warning**

Ensure that both flue test point plugs are in place after checking combustion.

Setting maximum and minimum output

1. Turn both control knobs fully anticlockwise and leave for 10 seconds.
2. Turn the DHW knob (🚰) $\frac{1}{4}$ turn twice in quick succession (within 2 seconds).
3. "304" will appear in the display.
4. Turn the CH knob (🔥) fully clockwise. "100" will appear in the display, indicating maximum output.
5. After checking at maximum turn the CH knob (🔥) fully anticlockwise. "0" will appear in the display, indicating minimum output.

Measuring the combustion

Turn on the domestic hot water tap. Carry out inlet working gas pressure, gas rate and combustion checks.

Once all relevant tests are completed, take out of chimney sweep mode by turning the DHW control knob clockwise.

Boiler is now ready to use.

PN-0000364

Fig.46 Combustion procedure

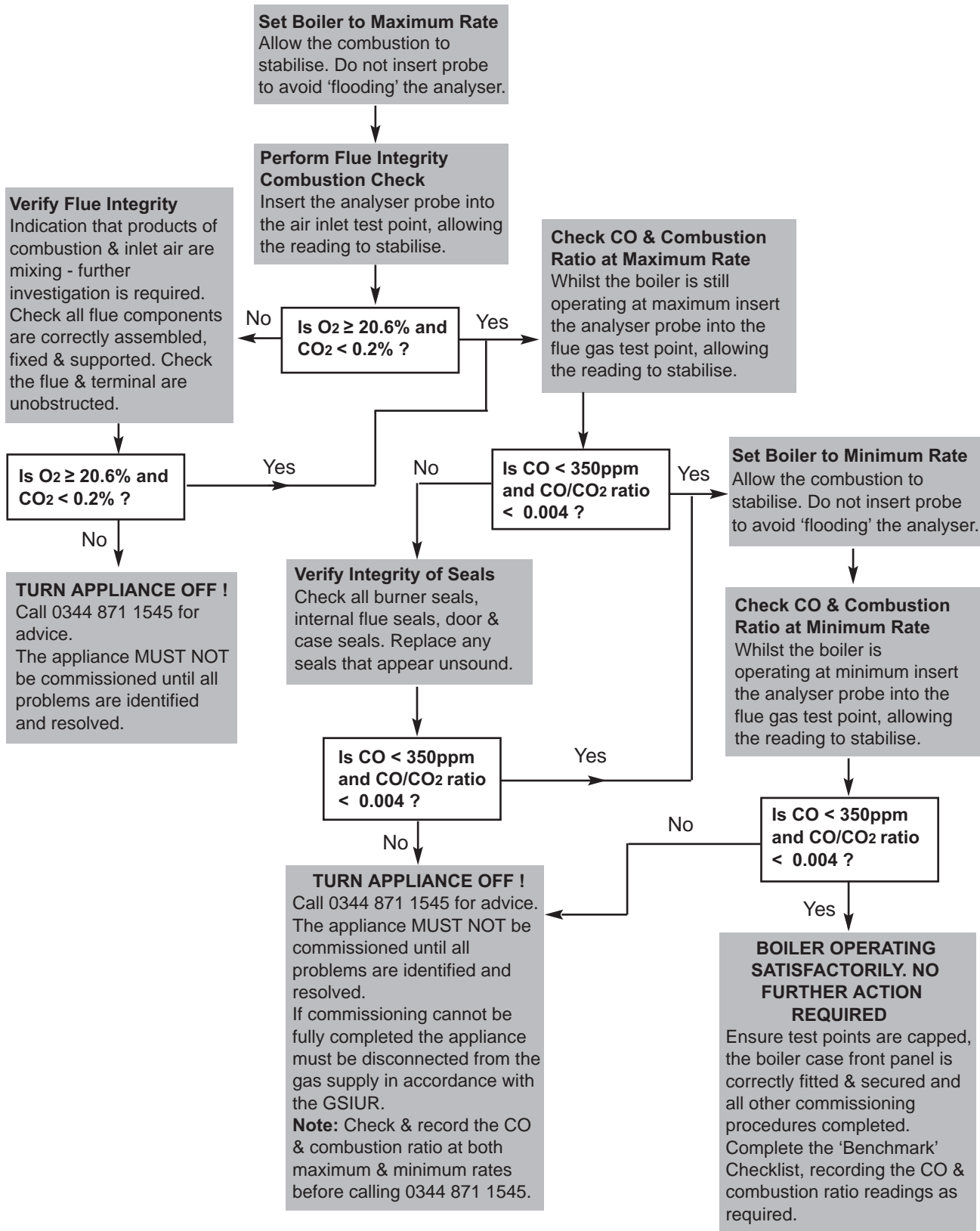

PN-000466

7.5 Configuring the system

7.5.1 System draining

If at any time after installation it is necessary to drain and refill the central heating system (e.g. when replacing a radiator) the De-Aeration function must be activated to avoid air being trapped in the system.



See

De-Aeration function, page 48.

Once De-Aeration is complete recommission the boiler and check that the inhibitor concentration is sufficient.

7.6 Final instructions

Fig.47 People

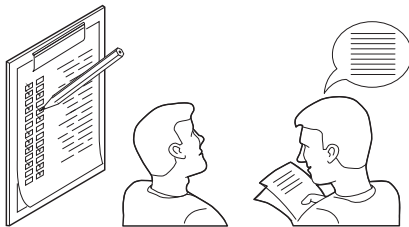

PN-0000333

7.6.1 Handover

1. Carefully read and complete all sections of the Benchmark Commissioning Checklist at the rear of this publication that are relevant to the boiler and installation. These details will be required in the event of any warranty work.

Important

The warranty will be invalidated if the Benchmark section is incomplete.

2. The publication must be handed to the user for safe keeping and each subsequent regular service visit recorded.
3. Hand over the User's Operating, Installation and Servicing Instructions, giving advice on the necessity of regular servicing.
4. **For IE**, it is necessary to complete a "Declaration of Conformity" to indicate compliance with I.S. 813. An example of this is given in I.S. 813 "Domestic Gas Installations". This is in addition to the Benchmark Commissioning Checklist.
5. Set the central heating and hot water temperatures to the requirements of the user. Instruct the user in the operation of the boiler and system.
6. Instruct the user in the operation of the boiler controls.
7. Demonstrate to the user the action required if a gas leak occurs or is suspected. Show them how to turn off the gas supply at the meter control, and advise them not to operate electric light or power switched, and to ventilate the property.
8. Show the user the location of the system control isolation switch, and demonstrate its operation.
9. Advise the user that they may observe a plume of vapour from the flue terminal, and that it is part of the normal operation of the boiler.

8 Operation

8.1 Use of the control panel

Fig.48 Control panel

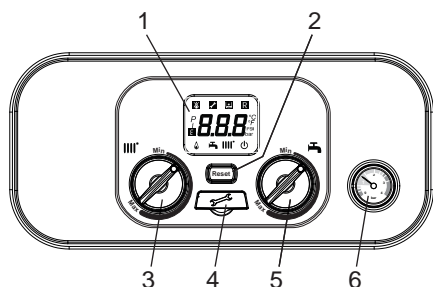

PN-0000334

8.1.1 Control panel

The controls are operated by the control knobs and a reset button.

- 1 Display screen
- 2 Reset button
- 3 CH temperature control knob
- 4 Service diagnostic port
- 5 DHW temperature control knob
- 6 System water pressure gauge

Important

When an OpenTherm controller is connected adjustment of the boiler, e.g. heating temperature, is made using the OpenTherm controller rather than the boiler controls. The boiler controls are overridden by the OpenTherm control. Please check the functionality with the manufacturer of the OpenTherm controller.

8.2 Start up



If there is no power to the boiler, switch on at the fused spur unit and ensure that the time control is in the on position and any other controls (e.g. room thermostat) are calling for heat. The boiler will begin its start sequence. This procedure performs a series of tests, after which the installation is purged (this takes approximately five minutes).

8.3 Frost protection

Where possible, draining the system should be avoided. If the system is to be unused during winter months several precautions must be taken:

Any parts of the system that are in unheated areas of the dwelling should be fitted with a device such as a pipe thermostat or frost thermostat.

Power must remain supplied to the boiler and controls.

Gas must remain supplied to the boiler.

The boiler pump will operate if the system temperature drops below 7°C. If the temperature falls to 4°C the burner will ignite and remain lit until the temperature reaches 10°C. At this temperature the burner will extinguish but the pump will continue to operate for 15 minutes. This feature will protect the boiler and to some extent adjacent parts of the system but additional devices must be incorporated to guarantee frost protection.

9 Maintenance

9.1 General



Warning

When changing components ensure that both the gas and electrical supplies to the boiler are isolated before any work is started. When the component has been changed recommission the boiler. Always examine any seals or gaskets, replacing where necessary. The case front panel **MUST** seal effectively against the boiler side panels.



Warning

After servicing or performing any maintenance on the boiler ensure that

Both flue test point plugs are in place

The front cover is correctly fitted

The front cover securing screws are fully tightened

For reasons of safety and economy, it is recommended that the boiler is serviced annually. Servicing must be performed by a competent person in accordance with BS 7967-4.

After servicing, complete the relevant Service Interval Record section of the Benchmark Commissioning Checklist at the rear of this publication.

Important

During routine servicing, and after any maintenance or change of part of the combustion circuit, the following must be checked:-

The integrity of the complete flue system and the flue seals by checking air inlet sample to eliminate the possibility of recirculation. **O₂ ≥ 20.6% & CO₂ < 0.2%**

The integrity of the boiler combustion circuit and relevant seals.

The operational gas inlet pressure and the gas rate.

The combustion performance as described in "Check the Combustion Performance" below.

Competence to carry out checking combustion performance BS 6798

"Specification for Installation & Maintenance of Gas Fired Boilers not exceeding 70kWh" advises that:-

The person carrying out a combustion measurement should have been assessed as competent in the use of a flue gas analyser and the interpretation of the results.

The flue gas analyser used should be one meeting the requirements of BS 7927 or BS-EN50379-3 and be calibrated in accordance with the analyser manufacturers' requirements.

Competence can be demonstrated by satisfactory completion of the CPA1 ACS assessment, which covers the use of electronic portable combustion gas analysers in accordance with BS 7967, Parts 1 to 4.

Check the Combustion Performance (CO/CO₂ ratio)

Set the boiler to operate at maximum rate.



See

Checking combustion - chimney sweep mode, page 49 for details.

Fig.49 Flue adaptor test points

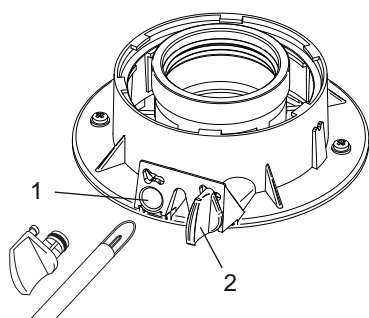

PN-0000363

Remove the plug from the combustion test point, insert the analyser probe and obtain the CO/CO₂ ratio. **This must be less than 0.004**. If the combustion reading (CO/CO₂ ratio) is greater than this, and the integrity of the complete flue system and combustion circuit seals has been verified, and the inlet gas pressure and gas rate are satisfactory either:-

Perform the "Standard Inspection and Maintenance".
 Perform "Setting the Gas Valve".
 Replace and set the gas valve.

- 1 Combustion test point
- 2 Incoming air for combustion test point

**Warning**

Ensure that both flue test point plugs are in place after checking combustion.

9.2 Standard inspection and maintenance operations

9.2.1 Annual Servicing

**Warning**

Ensure that the boiler is cool. Ensure that both the gas and electrical supplies to the boiler are isolated.

**Caution**

Always examine any seals or gaskets, replacing where necessary. Where a seal or gasket is supplied with a spare part it should be used, irrespective of the condition of the original. Use only original spare parts that are intended for use with this type of boiler.

Important

When performing any inspection or maintenance, personal protective equipment must be used where appropriate.

Fig.50 Remove the condensate trap

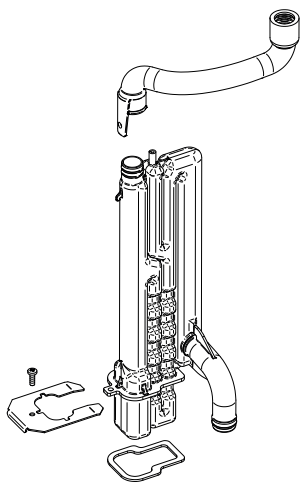

PN-0000381

1. Ensure that both the gas and electrical supplies to the boiler are isolated and that the boiler is cool.
2. Remove the case front panel and hinge down the control panel.

**See**

Specific maintenance instructions, page 57

3. Disconnect the pipe from the top of the condensate trap and the drain pipe from the condensate drain pipe connection. Undo the screw securing the bracket and trap to the boiler lower panel.
4. Remove the trap. Take care not to spill any residual condensate on the controls and P.C.B. Thoroughly rinse the trap and examine the gasket on the trap base, replacing if necessary.
5. Remove the clip securing the gas feed pipe to the air/gas venturi on the fan. Disconnect the pipe. Do not break the joint between the pipe and gas valve unless necessary.
6. Disconnect the electrode lead and the fan electrical plug.
7. Undo the four nuts retaining the burner / door assembly to the heat exchanger.
8. Carefully draw the burner / door assembly forward and remove.

**See**

Checking the burner and cleaning the heat exchanger, page 56

9. Clean any debris from the heat exchanger and check that the gaps between the tubes are clear.
10. Inspect the burner, insulation and position and condition of the electrode, cleaning or replacing if necessary. Clean any dirt or dust from the airbox.

11. Carefully examine all seals and gaskets, replacing if necessary. Look for any evidence of leaks or corrosion and if found determine and rectify the cause.
12. Reassemble in reverse order.
13. Complete the relevant Service Interval Record section of the Benchmark Commissioning Checklist at the rear of this publication and then hand it back to the user.

9.2.2 Checking the water pressure

In order for the boiler to operate correctly, the pressure of the water in the heating circuit must be between 1.0 and 1.5 bar. Restore the water pressure if necessary.

Fig.51 Restore water pressure



PN-0000382

9.2.3 Checking the expansion vessel

Check the expansion vessel and recharge or replace it if necessary. Check its pre-charge every year and restore the pressure to 1 bar if necessary.

9.2.4 Checking the automatic air vent

Check that the pump venting valve is working. In the event of a leak, replace the valve.

9.2.5 Checking the burner and cleaning the heat exchanger

Fig.52 Remove burner / door assembly

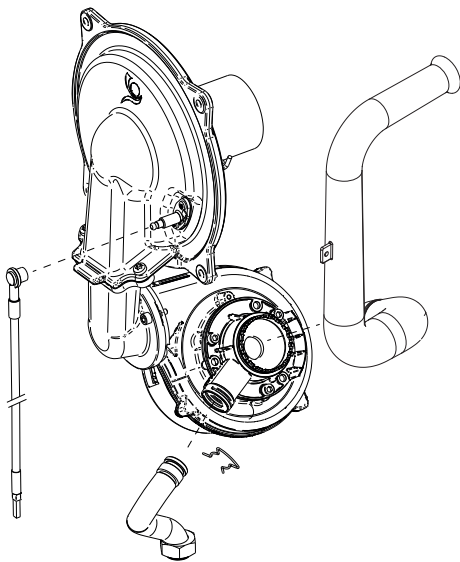

PN-0000394

1. Isolate the boiler from the gas & electrical supplies.
2. Remove the front panel.
3. Remove the silencer.
4. Disconnect the spark electrode lead and earth wire from the detection / spark electrode.
5. Remove the clip securing the gas feed pipe to the fan. Disconnect the pipe.
6. Completely remove the combustion chamber / burner door assembly by unscrewing the four M6 nuts and drawing it forwards to disengage it from the heat exchanger..
7. Check that the detection/spark electrode is not worn. Replace the electrode if necessary.
8. Check the condition of the burner, the gasket and the insulation board.
9. Any loose deposits in the heat exchanger should be removed using a vacuum cleaner.
10. A brush with plastic bristles can be used to dislodge any stubborn deposits, which should then also be removed by vacuum.
11. Do not use any chemicals to clean the heat exchanger.
12. The burner does not require any maintenance as it is self-cleaning. Check that there are no cracks and/or other damage on the surface of the burner. If the burner is damaged, replace it.
13. Reassemble in reverse order.

9.3 Specific maintenance instructions

Fig.53 Panel removal

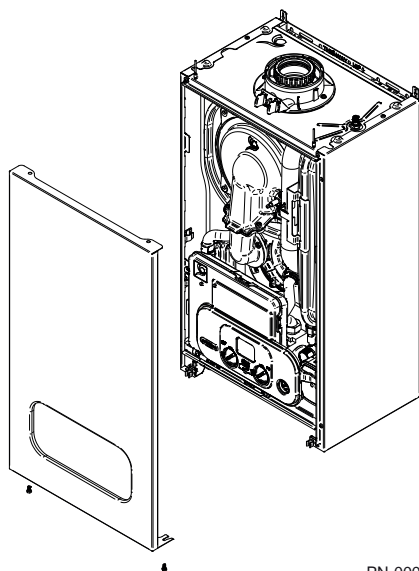

PN-0000323



Warning

When changing components ensure that both the gas and electrical supplies to the boiler are isolated before any work is started. When the component has been changed recommission the boiler. Always examine any seals or gaskets, replacing where necessary. The case front panel **MUST** seal effectively against the boiler side panels.

To remove the case front panel proceed as follows:

Unscrew the two screws located on the bottom of the front panel. Slide the bottom of the front panel forward and lift upwards to disengage the panel.
Hinge down the control panel.

Fig.54 Remove detection/spark ignition electrode

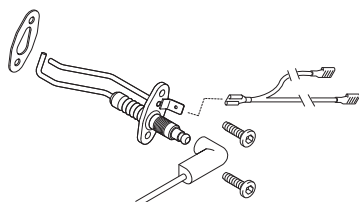

PN-0000331

9.3.1 Detection/spark ignition electrode

1. Disconnect the electrode lead and earthing cable.
2. Using a T15 Torx key, remove the retaining screws securing the electrode to the combustion chamber door and remove the electrode, noting its orientation.
3. Fit the new electrode with the sealing gasket.
4. Reassemble in reverse order.

Fig.55 Remove NTC flue sensor

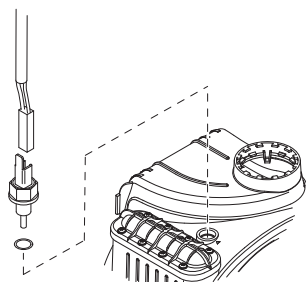

PN-0000332

9.3.2 NTC flue sensor

1. Turn the sensor 90° anticlockwise to remove — it is a bayonet connection.
2. Ease the retaining tab on the sensor away and disconnect the electrical plug.
3. Fit new sensor and reassemble in reverse order.

Fig.56 Remove flow and return sensors

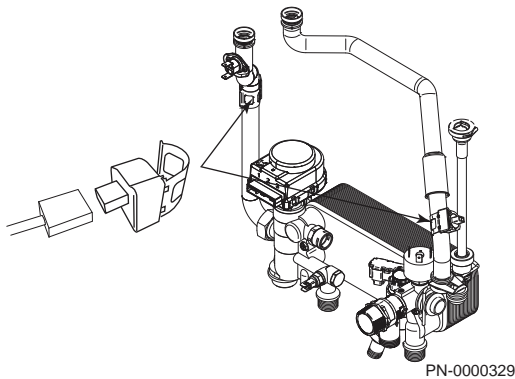

9.3.3 Flow and return sensors

There is one sensor on the flow (red wires) and one sensor on the return (blue wires).

1. After noting the position of each sensors, prise the sensor clip off the pipe and disconnect the plug.
2. Connect the plug to the new sensor and ease the clip onto the pipe in its original position.

Fig.57 Removing safety overheat thermostat

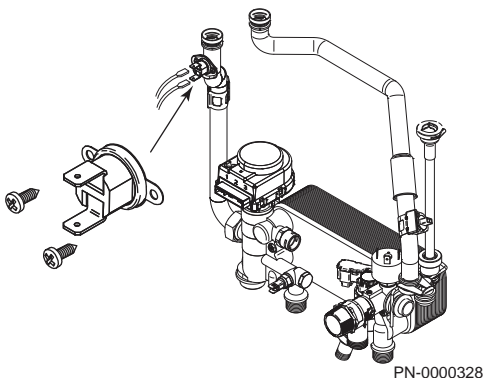

9.3.4 Safety overheat thermostat

1. Pull the two spade connections off the safety overheat thermostat.
2. Remove the screws securing the thermostat to the mounting plate on the flow pipe and remove it.
3. Fit the new safety overheat thermostat to the mounting plate with the two screw previously removed.
4. Connect the two spade connections to the safety overheat thermostat ensuring that they are pushed fully on.

Fig.58 Remove DHW temperature sensor

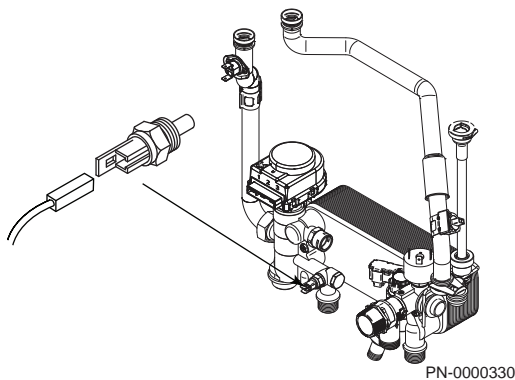

9.3.5 DHW temperature sensor (NTC)

1. Turn off the mains cold water supply tap and draw off the residual domestic hot water.
2. Ease the retaining tab on the sensor away and disconnect the electrical plug.
3. Unscrew the sensor from the plate heat exchanger manifold. Examine the sealing washer, replacing if necessary.
4. Reassemble in reverse order with the new sensor. The plug will only fit one way.

9.3.6 Pressure Gauge

1. Drain the primary circuit and undo the nut on the pressure gauge capillary.
2. Ease the two retaining tabs holding the pressure gauge bracket away and remove the bracket.
3. Remove the gauge assembly.
4. Examine the sealing washer on the pressure gauge capillary, replace if necessary.
5. Reassemble in reverse order with the new pressure gauge.

Fig.59 Remove hall effect sensor

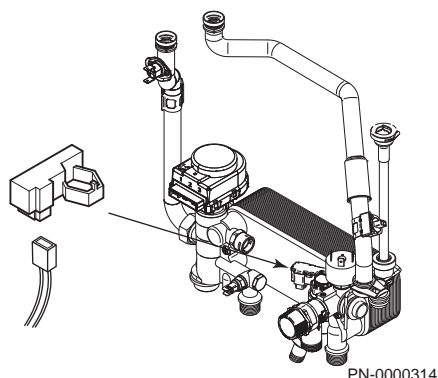

9.3.7 Hall effect sensor

1. Ease the sensor upwards off the hydraulic inlet manifold assembly.
2. Disconnect the electrical plug from the sensor.
3. Connect the plug to the new sensor. Carefully fit the new sensor to the hydraulic assembly, ensuring it is fully down.

Fig.60 Remove flow regulator and filter

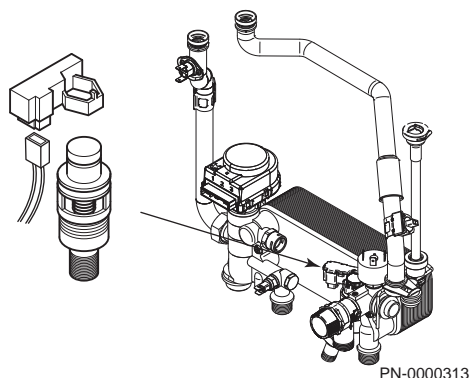

9.3.8 DHW flow regulator and filter

1. Close the cold mains inlet and draw off any residual DHW.
2. Pull off the hall effect sensor.
3. Unscrew the filter assembly from the inlet / return manifold.

Fig.61 Remove safety pressure relief valve

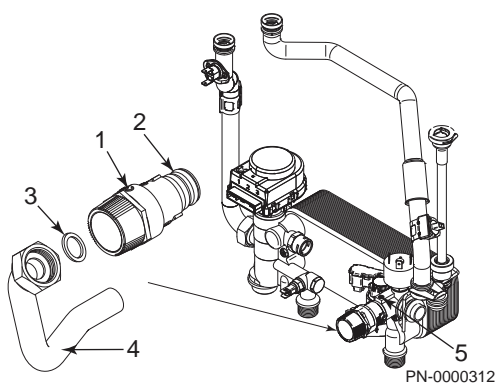

9.3.9 Safety pressure relief valve

1	Safety pressure relief valve
2	"O" ring seal
3	Sealing grommet
4	Discharge pipe
5	Grub screw

1. Drain the primary circuit.
2. Disconnect the discharge pipe from the valve and remove the sealing grommet.
3. Using a suitable hexagon key undo the grub screw sufficiently to release the valve.
4. Note the orientation of the valve, rotate it and withdraw it from the manifold.
5. Fit the new valve and 'O' ring seal and set to the previously noted orientation. Tighten the grub screw.
6. Reconnect the discharge pipe ensuring the sealing grommet is in place to maintain the integrity of the case seal.

Fig.62 Remove diverter valve

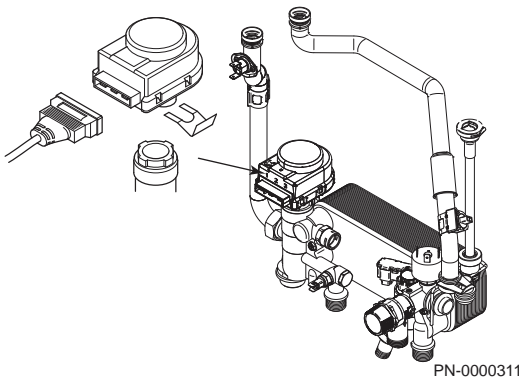

9.3.10 Diverter valve motor

1. Disconnect the multi-pin plug from the diverter valve motor.
2. Hold the motor in place against the spring pressure of the valve assembly, remove the securing clip.
3. Remove the motor.
4. When fitting the new motor it will be necessary to hold the unit firmly while depressing the valve assembly spring to refit the securing clip.
5. Reconnect the multi-pin plug.

Fig.63 Remove expansion vessel

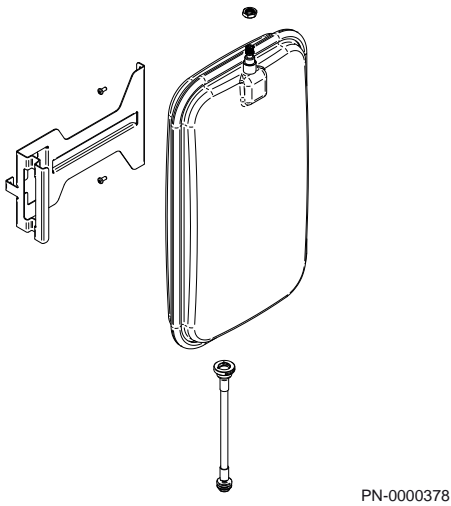

9.3.11 Expansion vessel

Warning
 Take precautions to protect other components from water damage when removing the expansion vessel.

1. Close the flow and return isolation taps and drain the boiler primary circuit.
2. Relieve the pressure from the expansion vessel.
3. Remove the silencer.
4. Prise off the securing clips and disconnect the braided hose from the vessel and hydraulic inlet assembly, taking care as water may still be in the vessel.
5. Ensure that the braided hose is free of restriction, as a boiler with a blocked hose will exhibit symptoms similar to one with a failed vessel.

Important
 Where the hose is found to be blocked, it must be cleared or replaced and the vessel recharged to 1 bar.

6. If the hose is clear support the vessel, undo the locknut and manoeuvre the vessel out of the boiler.
7. Replace the expansion vessel with the new one and reassemble in reverse order and recharge to 1 bar.

i 9.3.12 Gas valve

Tab.23 Characteristics of combustion

Main Eco Compact Combi		25	30
CO ₂	% (maximum)	9.0 + 0.3 – 0.2	9.0 + 0.3 – 0.2
	% (minimum)	8.5 + 0.1 – 0.4	8.5 + 0.1 – 0.4
Diameter of coaxial discharge pipes	mm	60/100 & 80/125	60/100 & 80/125

Fig.64 Removing the gas valve

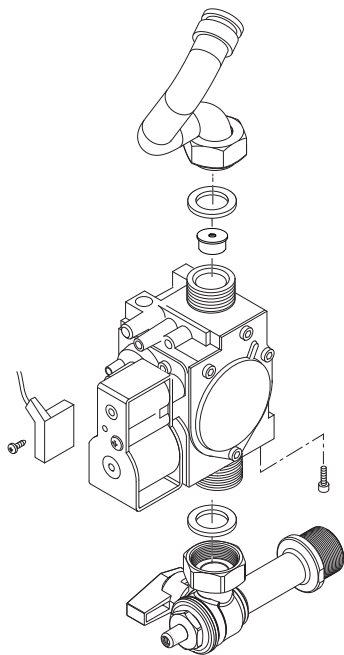

PN-0000308

Important

After replacing the gas valve the CO₂ must be checked and adjusted. Only change the valve if a suitable calibrated combustion analyzer is available, operated by a competent person.

1. Undo the screw and disconnect the electrical plug.
2. Turn the gas cock off and undo the nut on the gas valve inlet underneath the boiler.



3. Undo the nut on the gas valve outlet. Ease the pipe aside.

Important

The gas nozzle injector is inserted in the gas valve outlet.

4. Remove the screws securing the gas valve to the boiler bottom panel. Remove the valve.
5. Transfer the gas nozzle injector to the new valve, ensuring it sits in the valve outlet. Examine the sealing washers, replacing if necessary.



6. Reassemble in reverse order.

Important

Check gas tightness and combustion.



Fig.65 Setting the gas valve

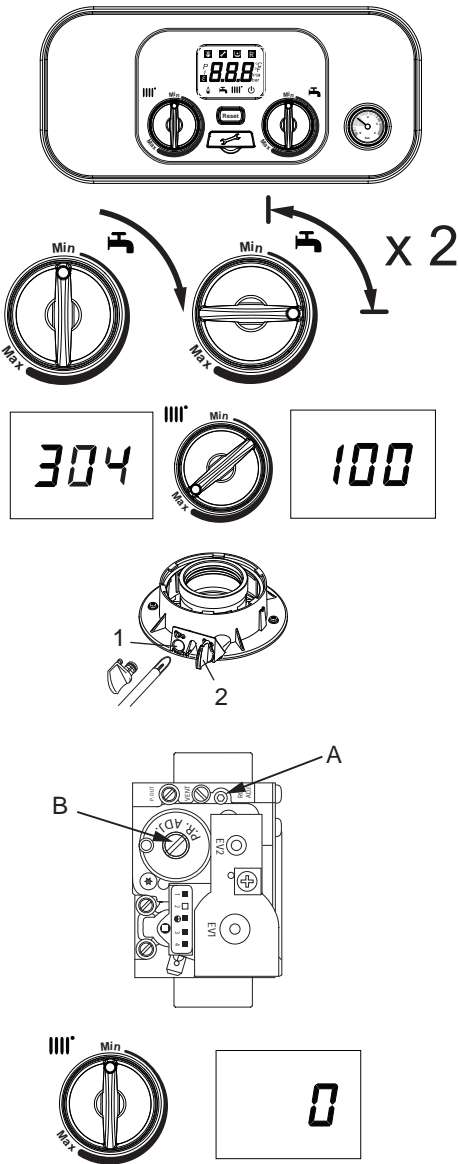

PN-0000376

Setting the gas valve (CO₂)

Important

The CO₂ must be only checked and adjusted to set the valve if a suitable calibrated combustion analyser is available, operated by a competent person.



See
Annual Servicing, page 55

- i** The combustion (CO₂) may be checked after running the boiler for several minutes. To do this it is necessary to set the boiler to "Calibration Mode".
2. **Ensure that all external controls are calling for heat.** The actual current boiler temperature is shown on the display.
3. **Turn both control knobs fully anticlockwise**, then quickly turn the right hand knob 1/4 clockwise twice and back in quick succession (within 2 seconds). "304" will appear in the display screen.
4. Turn the left hand knob fully clockwise. "100" will appear in the display screen, indicating maximum output.

1	Combustion test point
2	Incoming air for combustion test point
A	Throttle Adjustment Screw
B	Offset Adjustment Screw

5. Remove the plug from the flue sampling test point. Insert the analyser probe and allow sufficient time for the reading to settle.

Main Eco Compact		25 - 30
CO ₂	% (maximum)	9.0 + 0.3 – 0.2

6. It is possible to alter the CO₂ by adjustment of the gas valve. Remove the plastic cover from the Throttle Adjustment Screw. At maximum rate the throttle adjustment screw should be turned, using a suitable hexagon key, until the correct reading is obtained.
 - Turning clockwise will reduce the CO₂.
 - Turning anticlockwise will increase the CO₂.
7. The CO₂ must then be checked at minimum rate. Turn the left hand knob fully anticlockwise. As the knob is turned the display will change, indicating the fan speed. When the display reads "0" the boiler runs at minimum rate.

Main Eco Compact		25 - 30
CO ₂	% (minimum)	8.5 + 0.1 — 0.4

8. With the boiler on minimum, the Offset Adjustment Screw must be altered, using a suitable hexagon key, after removing the cap.
 - Turning clockwise will increase the CO₂.
 - Turning anticlockwise will reduce the CO₂.
9. The calibration function is maintained for 20 minutes unless the maximum central heating temperature is exceeded. The function can be disabled at any time by turning the right hand knob.
10. **Check the combustion performance (CO/CO₂ ratio). This must be less than 0.004.**

**Warning**

Ensure that both flue test point plugs are in place after checking combustion.

Fig.66 Remove pump head only

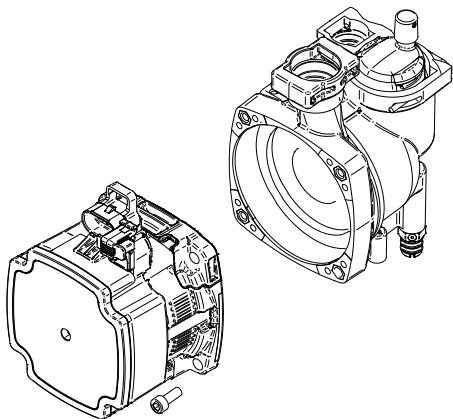

PN-0000380

9.3.13 Pump - head only

To remove the pump head only.

1. Drain the boiler primary circuit and disconnect the electrical plug from the pump
2. Remove the socket head screws securing the pump head to the body and draw the head away.
3. Fit the new pump head and reassemble in reverse order.

9.3.14 Pump - complete

**Warning**

Take precautions to protect other components from water damage when removing the pump and auto air vent.

Fig.67 Remove pump

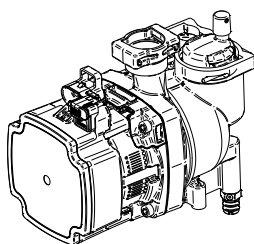

PN-0000379

1. Hinge the control box down.
2. Close the flow and return isolation taps and drain the boiler primary circuit.
3. Disconnect the electrical plugs from the pump motor.
4. Prise off the securing clip that is holding the pump return pipe in position. Pull away the pipe.
5. Pull out the securing clip that is holding the pump body to the hydraulic inlet assembly.
6. Prise off the securing clip and disconnect the braided hose from the pump body, taking care as water may still be in the hose.
7. Remove the screws securing the pump to the boiler bottom panel.
8. The pump should now be able to be removed.
9. Pull out the securing clip and remove the automatic air vent, transferring it to the new pump body.
10. Examine all 'O' ring seals, replace if necessary and reassemble in reverse order.

10 Troubleshooting

10.1 Error codes

10.1.1 Initial error fault finding checks

Check that gas, water and electrical supplies are available at the boiler.
 Electrical supply = 230V ~ 50 Hz.
 The minimum gas pressure at the meter is 19mb.
 Carry out electrical system checks, i.e. Earth Continuity, Resistance to Earth, Short Circuit and Polarity with a suitable meter.
 Ensure all external controls are calling for heat and check all external and internal fuses.

Important

These checks must be repeated after any servicing or fault finding.

10.1.2 Display of error codes

If a fault occurs on the boiler an error code may be shown by the display screen.

The codes are a flashing number, either two or three digit, preceded by the symbol **E** :-

- E** followed by 20, 28, 40, 160 or 321 indicates possible faulty components.
- E** 110 indicates overheat of the primary system water.
- E** 118 is displayed when the primary water pressure is less than 0.5 bar.
- E** 133, 134 and 135 indicates that the gas supply has been interrupted, ignition has failed or the flame has not been detected.
- E** 128 is displayed if there has been a flame failure during normal operation.
- E** 125 is displayed in either of two situations:-
 - If between 15 and 30 seconds of the burner lighting, the primary water temperature has not changed by 1° C.
 - If within 10 minutes of the burner lighting, the primary water temperature actual temperature twice exceeds the selected temperature by 30°. In these instances poor primary circulation is indicated.
- E** 103, 104 & 107 and "Bat" are errors related to the optional Safety Assist accessory (see the manual supplied with the accessory)

By pressing the **Reset** button for 1 to 3 seconds when **E** 09, 15, 110, 125, 128, 133, 134, 135, 384 are displayed it is possible to relight the boiler.

If this does not have any effect, or the codes are displayed regularly further investigation is required.

Fig.68 Display of error codes

Error code	Description of fault
E 09	Gas valve connection cable
E 15	Gas valve fault
E 20	Central heating NTC fault
E 28	Flue NTC fault
E 40	Central heating return NTC fault
E 83	Communication error
E 109	Pre-circulation fault
E 110	Safety thermostat operated
E 118	Primary system water pressure too low
E 125	Circulation fault (primary)
E 128	Flame failure
E 130	Flue NTC operated
E 133	Interruption of gas supply or flame failure
E 135	Interruption of gas supply (internal error)
E 154	Flow / return sensor temperature test
E 160	Fan or fan wiring fault
E 270	Circulation fault (Dry fire)
E 321	Hot water NTC fault
E 384	False flame

PN-0000377

10.2 Fault finding

10.2.1 Central heating

Fig.69 Central heating — Follow operational sequence

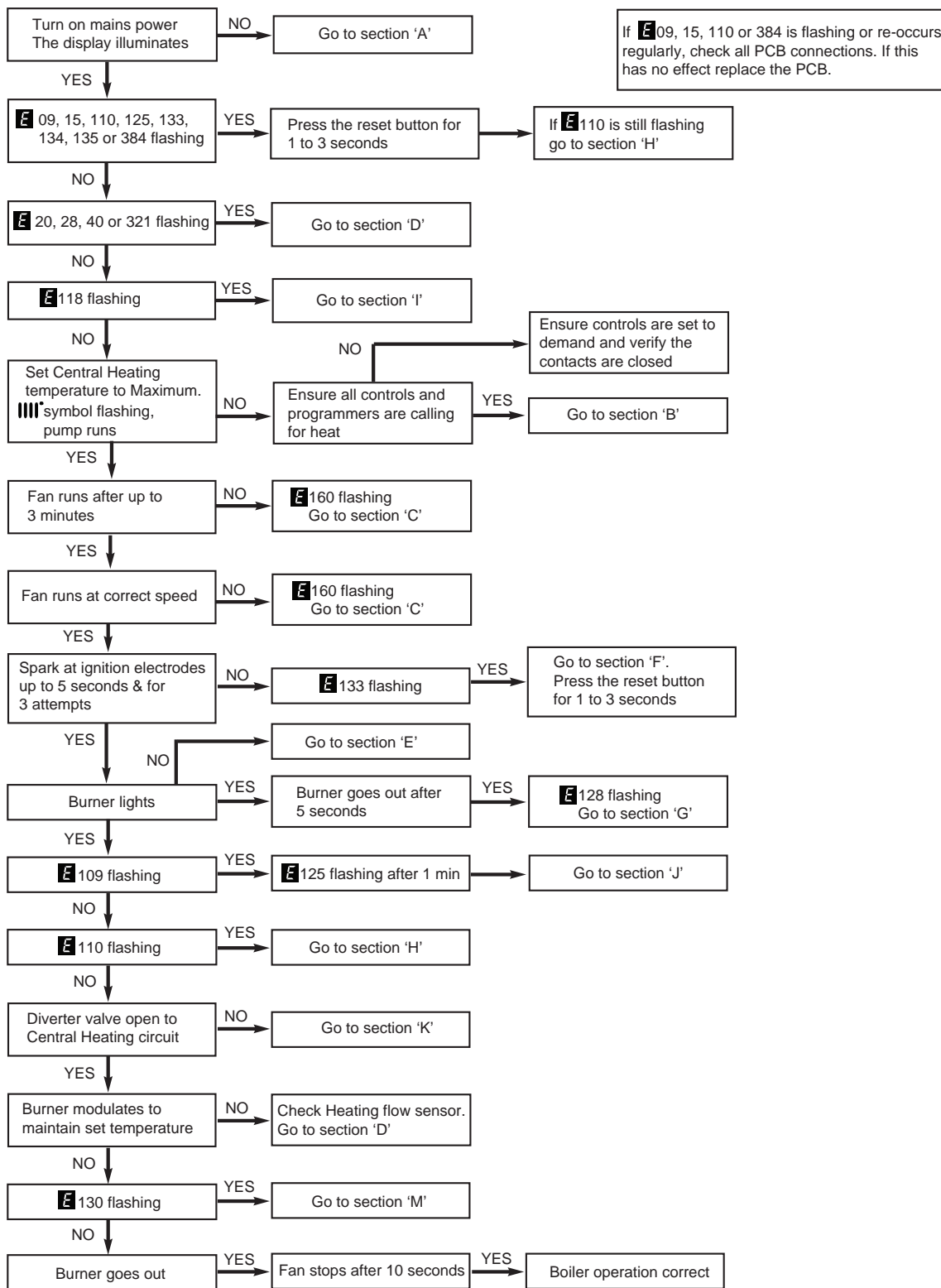

PN-0000315



See

Electrical diagram, page 18 for position of terminals and components.

10.2.2 Domestic hot water

Fig.70 Domestic hot water — Follow operational sequence

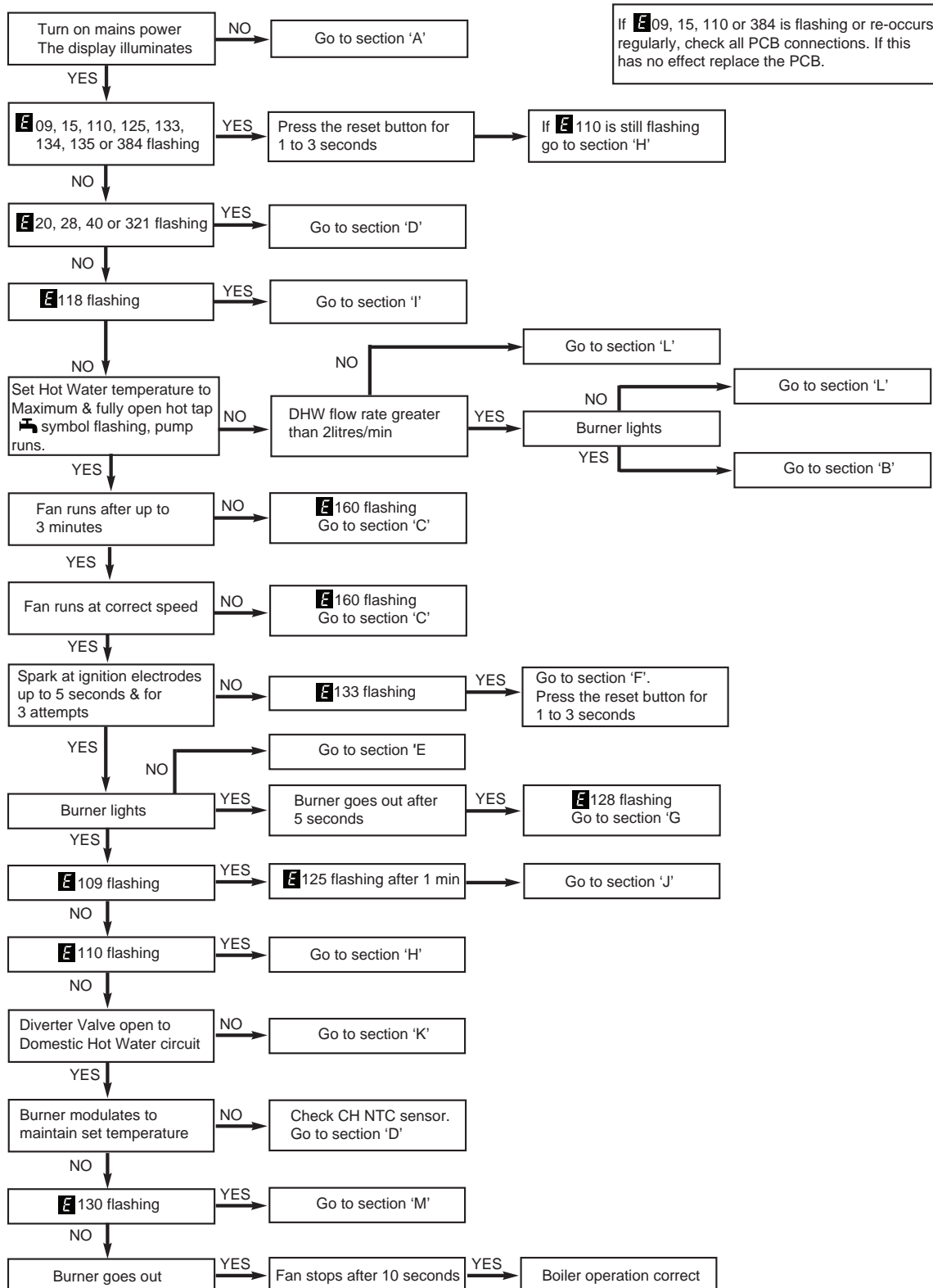

10.2.3 Fault finding solutions sections A to E

Fig.71 Solutions sections A to E

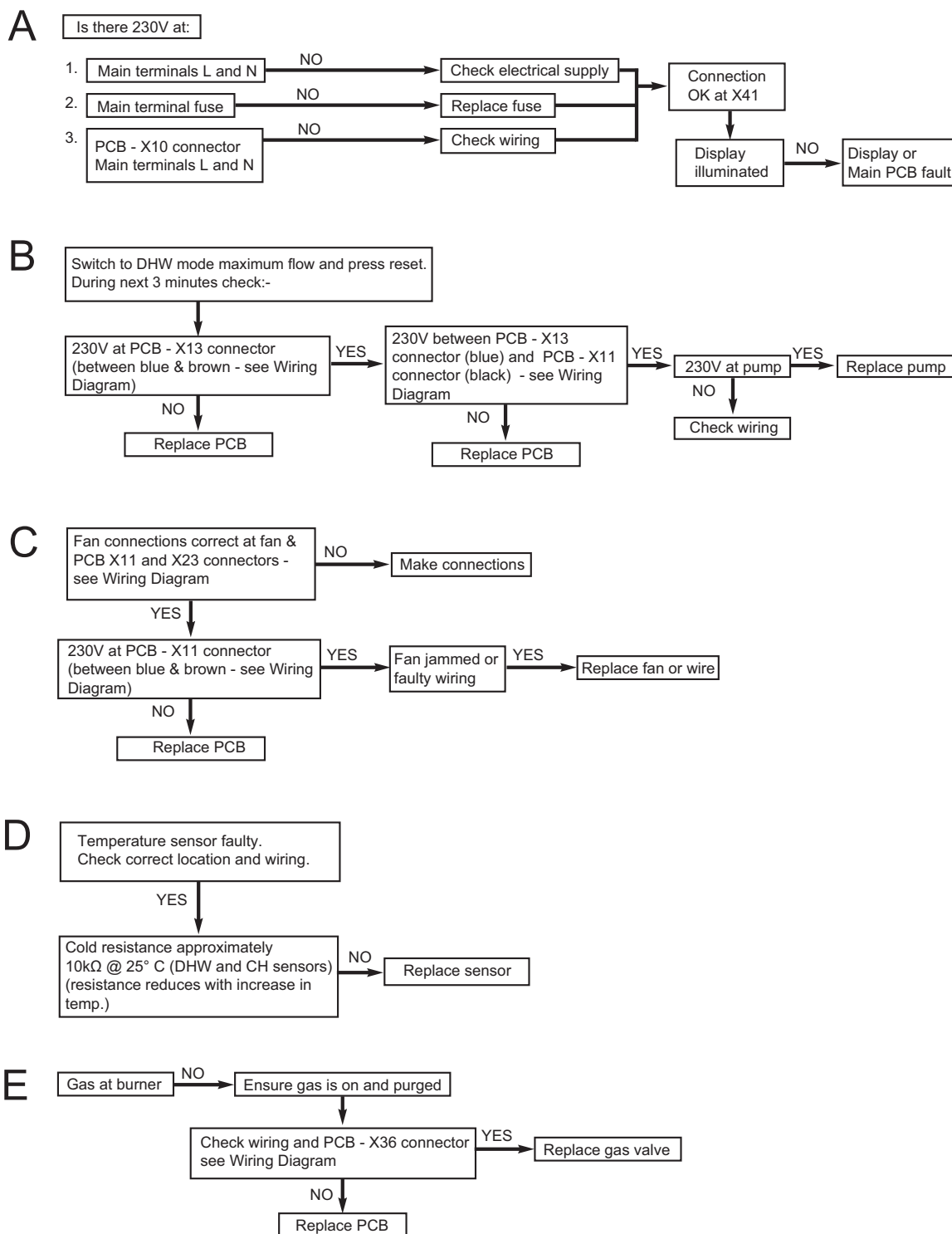

PN-0000317

10.2.4 Fault finding solutions sections F to H

Fig.72 Solutions sections F to H

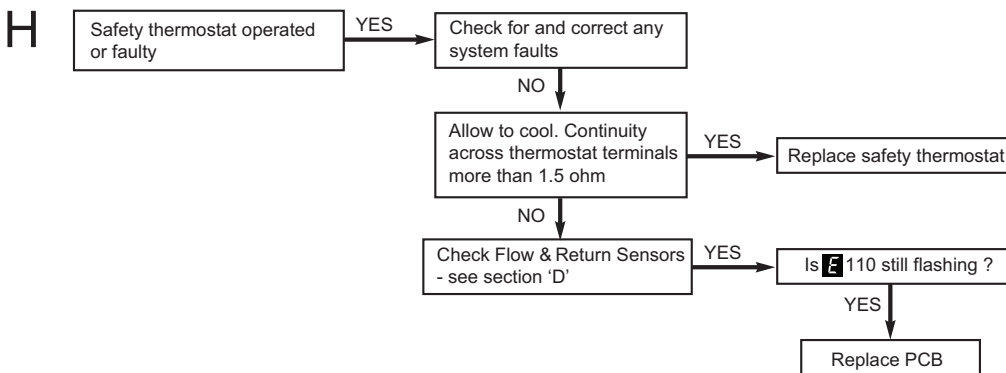
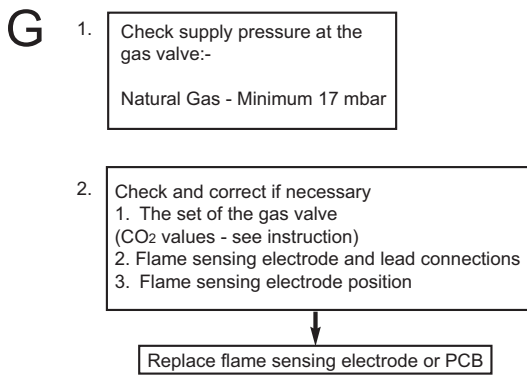
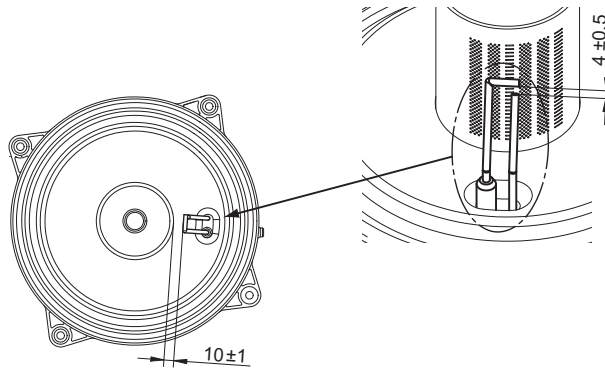
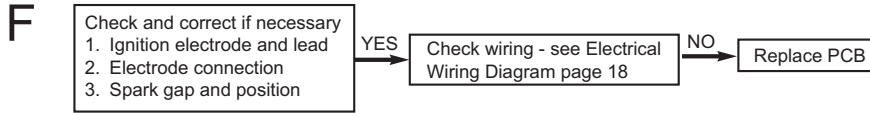

10.2.5 Fault finding solutions sections I to M

Fig.73 Solutions sections I to M

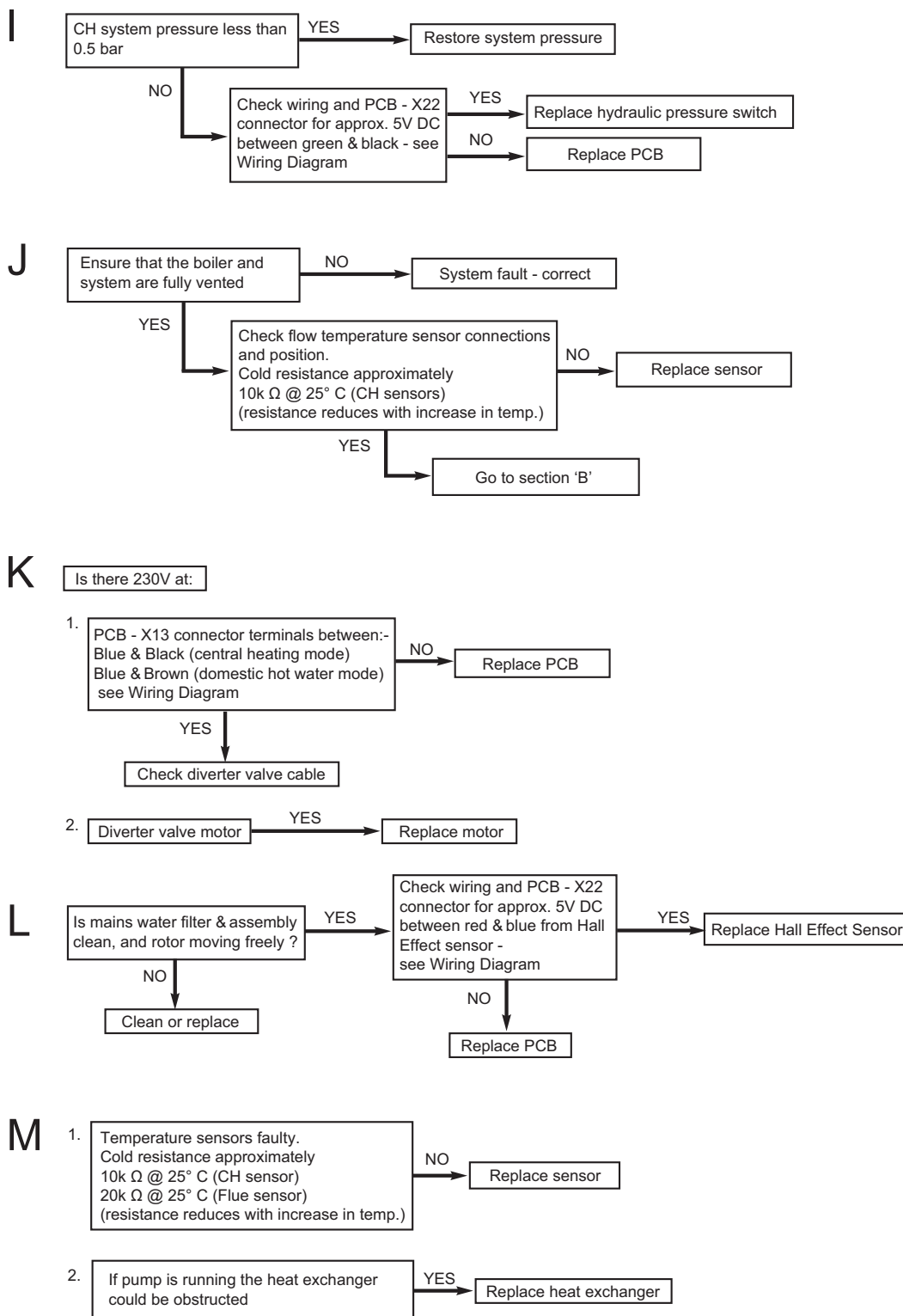

11 Decommissioning

11.1 Decommissioning procedure

Disconnect the gas & electric supplies and isolate them.

Drain the primary circuit and disconnect the filling device.

Dismantle the chimney system and remove the boiler from the wall mounting frame.

12 Disposal

12.1 Disposal and recycling

**Caution**

Removal and disposal of the boiler must be carried out by a qualified person in accordance with local and national regulations.

13 Spare parts

13.1 Short parts list

Fig.74 Spare parts

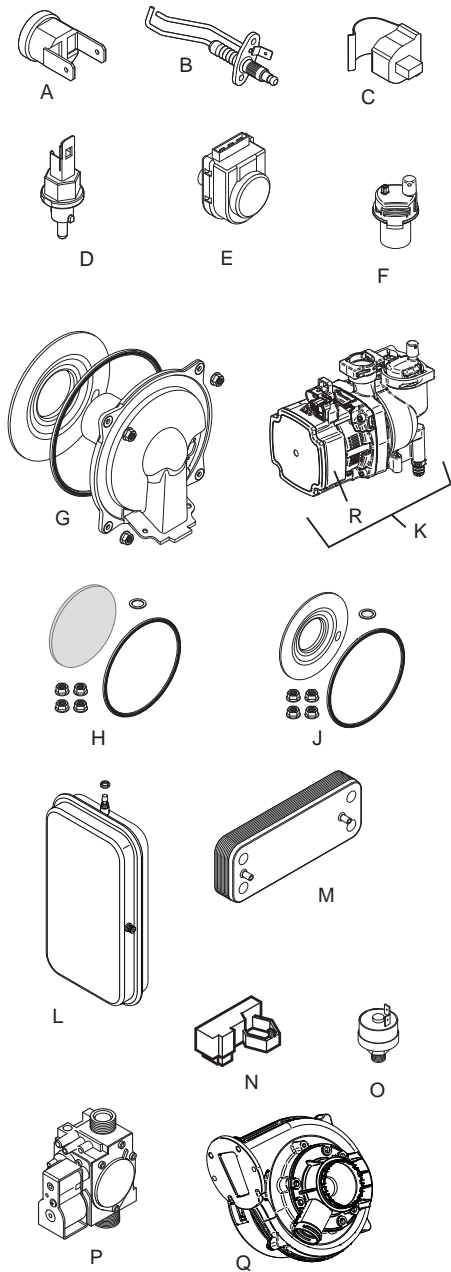

PN-0000365

The following spares are available:

Tab.24 Part number and description of spare parts

Key No.	Description	Manufacturer's Spare Part No.
A	Safety thermostat	7207653
B	Detection / spark ignition electrode	7686344
C	Flow sensor and return sensor	7207471
D	NTC flue sensor	7207892
E	Diverter valve motor	7216534
F	Auto air vent	7207776
G	Burner / door assembly	7686323
H	Insulation rear	7661741
J	Insulation front	7661745
K	Pump assembly	7684006
L	Expansion vessel	7683801
M	Plate heat exchanger	7683965
N	Hall effect sensor	7207880
O	Hydraulic pressure switch	5114748
P	Gas valve	7683968
R	Pump head	7686336
Q	Fan	7683926

14 Appendix

14.1 Benchmark commissioning checklist



Warning

After servicing or performing any maintenance on the boiler ensure that

- Both flue test point plugs are in place
- The front cover is correctly fitted & the securing screws are fully tightened

This Commissioning Checklist is to be completed in full by the competent person who commissioned the boiler as a means of demonstrating compliance with the appropriate Building Regulations and then handed to the customer to keep for future reference.

Failure to install and commission according to the manufacturer's instructions and complete this Benchmark Commissioning Checklist will invalidate the warranty. This does not affect the customer's statutory rights.

Customer name:				Telephone number:				
Address:								
Boiler make and model:								
Boiler serial number:								
Commissioned by (PRINT NAME):				Gas Safe register number:				
Company name:				Telephone number:				
Company address:								
				Commissioning date:				
To be completed by the customer on receipt of a Building Regulations Compliance Certificate*								
Building Regulations Notification Number (if applicable):								
CONTROLS (tick the appropriate boxes)								
Time and temperature control to heating	Room thermostat and programmer/timer			Programmable room thermostat				
	Load/weather compensation			Optimum start control				
Time and temperature control to hot water	Cylinder thermostat and programmer/timer			Combination Boiler				
Heating zone valves	Fitted			Not required				
Hot water zone valves	Fitted			Not required				
Thermostatic radiator valves	Fitted			Not required				
Automatic bypass to system	Fitted			Not required				
Boiler interlock				Provided				
ALL SYSTEMS								
The system has been flushed and cleaned in accordance with BS7593 and boiler manufacturer's instructions							Yes	
What system cleaner was used?								
What inhibitor was used?							Quantity	litres
Has a primary water system filter been installed?							Yes	No
CENTRAL HEATING MODE measure and record:								
Gas rate	m ³ /hr			OR		ft ³ /hr		
Burner operating pressure (if applicable)	mbar			OR Gas inlet pressure		mbar		
Central heating flow temperature						°C		
Central heating return temperature						°C		
COMBINATION BOILERS ONLY								
Is the installation in a hard water area (above 200ppm)?							Yes	No
If yes, and if required by the manufacturer, has a water scale reducer been fitted?							Yes	No
What type of scale reducer has been fitted?								
DOMESTIC HOT WATER MODE Measure and Record:								
Gas rate	m ³ /hr			OR		ft ³ /hr		
Burner operating pressure (at maximum rate)	mbar			OR Gas inlet pressure at maximum rate		mbar		
Cold water inlet temperature						°C		
Hot water has been checked at all outlets				Yes		Temperature	°C	
Water flow rate						l/min		
CONDENSING BOILERS ONLY								
The condensate drain has been installed in accordance with the manufacturer's instructions and/or BS5546/BS6798							Yes	

ALL INSTALLATIONS					
Record the following:	At max. rate:	CO	ppm	AND	CO/CO ₂ Ratio
	At min. rate: (where possible)	CO	ppm	AND	CO/CO ₂ Ratio
The heating and hot water system complies with the appropriate Building Regulations					Yes
The boiler and associated products have been installed and commissioned in accordance with the manufacturer's instructions					Yes
The operation of the boiler and system controls have been demonstrated to and understood by the customer					Yes
The manufacturer's literature, including Benchmark Checklist and Service Record, has been explained and left with the customer					Yes
Commissioning Engineer's Signature					
Customer's Signature					
(To confirm satisfactory demonstration and receipt of manufacturer's literature)					

*All installations in England and Wales must be notified to Local Authority Building Control (LABC) either directly or through a Competent Persons Scheme. A Building Regulations Compliance Certificate will then be issued to the customer.



© Heating and Hotwater Industry Council (HHIC)

www.centralheating.co.uk

14.2 Service records

It is recommended that your heating system is serviced regularly and that the appropriate Service Interval Record is completed.

Service Provider

Before completing the appropriate Service Record below, please ensure you have carried out the service as described in the manufacturer's instructions. Always use the manufacturer's specified spare part when replacing controls.

SERVICE 01					Date:
Engineer name:					
Company name:					
Telephone No:					
Gas safe register No:					
Record:	At max. rate:	CO	ppm	AND	CO ₂ %
	At min. rate: (Where Possible)	CO	ppm	AND	CO ₂ %
Comments:					
Signature					

SERVICE 02					Date:
Engineer name:					
Company name:					
Telephone No:					
Gas safe register No:					
Record:	At max. rate:	CO	ppm	AND	CO ₂ %
	At min. rate: (Where Possible)	CO	ppm	AND	CO ₂ %
Comments:					
Signature					

SERVICE 03					Date:
Engineer name:					
Company name:					
Telephone No:					
Gas safe register No:					
Record:	At max. rate:	CO	ppm	AND	CO ₂ %
	At min. rate: (Where Possible)	CO	ppm	AND	CO ₂ %
Comments:					
Signature					

SERVICE 04					Date:
Engineer name:					
Company name:					
Telephone No:					
Gas safe register No:					
Record:	At max. rate:	CO	ppm	AND	CO ₂ %
	At min. rate: (Where Possible)	CO	ppm	AND	CO ₂ %
Comments:					
Signature					

SERVICE 05					Date:
Engineer name:					
Company name:					
Telephone No:					
Gas safe register No:					
Record:	At max. rate:	CO	ppm	AND	CO ₂ %
	At min. rate: (Where Possible)	CO	ppm	AND	CO ₂ %
Comments:					
Signature					

SERVICE 06					Date:
Engineer name:					
Company name:					
Telephone No:					
Gas safe register No:					
Record:	At max. rate:	CO	ppm	AND	CO ₂ %
	At min. rate: (Where Possible)	CO	ppm	AND	CO ₂ %
Comments:					
Signature					

SERVICE 07					Date:
Engineer name:					
Company name:					
Telephone No:					
Gas safe register No:					
Record:	At max. rate:	CO	ppm	AND	CO ₂ %
	At min. rate: (Where Possible)	CO	ppm	AND	CO ₂ %
Comments:					
Signature					

SERVICE 08					Date:
Engineer name:					
Company name:					
Telephone No:					
Gas safe register No:					
Record:	At max. rate:	CO	ppm	AND	CO ₂ %
	At min. rate: (Where Possible)	CO	ppm	AND	CO ₂ %
Comments:					
Signature					

SERVICE 09					Date:
Engineer name:					
Company name:					
Telephone No:					
Gas safe register No:					
Record:	At max. rate:	CO	ppm	AND	CO ₂ %
	At min. rate: (Where Possible)	CO	ppm	AND	CO ₂ %
Comments:					
Signature					

SERVICE 10					Date:
Engineer name:					
Company name:					
Telephone No:					
Gas safe register No:					
Record:	At max. rate:	CO	ppm	AND	CO ₂ %
	At min. rate: (Where Possible)	CO	ppm	AND	CO ₂ %
Comments:					
Signature					

*All installations in England and Wales must be notified to Local Authority Building Control (LABC) either directly or through a Competent Persons Scheme. A Building Regulations Compliance Certificate will then be issued to the customer.



© Heating and Hotwater Industry Council (HHIC)

www.centralheating.co.uk



Warning

After servicing or performing any maintenance on the boiler ensure that

- Both flue test point plugs are in place
- The front cover is correctly fitted & the securing screws are fully tightened

© Copyright

All technical and technological information contained in these technical instructions, as well as any drawings and technical descriptions supplied, remain our property and shall not be multiplied without our prior consent in writing. Subject to alterations.

Baxi Customer Support



0344 871 1545

Opening hours

Monday - Friday, 8.00am-6.00pm

Weekends and Bank Holidays, 8.30am-2.00pm

Please note calls may be recorded for training and monitoring purposes



baxi.co.uk

Register now to activate your warranty:

www.baxi.co.uk/registration

For the warranty to be maintained, please make sure...

- 1 Benchmark checklist is completed
- 2 Warranty is registered within 30 days
- 3 The boiler has an annual service

For full terms and conditions, visit www.baxi.co.uk/terms. Failure to adhere to terms and conditions will void your manufacturer's warranty.



Baxi
Brooks House,
Coventry Road,
Warwick, CV34 4LL

CE
0085



Please ensure the boiler is installed in accordance with these installation instructions and that you adhere to the Building Regulations.



e&oe

All descriptions and illustrations provided in this document have been carefully prepared but we reserve the right to make changes and improvements in our products which may affect the accuracy of the information contained in this leaflet. All goods are sold subject to our standard Conditions of Sale which are available on request.

part of **BAXI**

7716573-02